



# The Relative Merits and Limitations of Thermal Fluid, Electric and Steam Heat Tracing Systems



Thermal Fluid



Electric



Steam

## TABLE OF CONTENTS

INTRODUCTION.....2

HEAT TRACING METHODS & HISTORY.....2, 3

**OVERVIEW:** TODAY’S THERMAL FLUID SYSTEMS.....3

**OVERVIEW:** TODAY’S ELECTRIC TRACING SYSTEMS .....4

**OVERVIEW:** TODAY’S STEAM TRACING SYSTEMS..... 5-7

**OVERVIEW:** FREE STEAM .....7

SOME BASIC COMPARISONS..... 8

THERMAL FLUID TRACING MERITS.....8

THERMAL FLUID TRACING LIMITATIONS.....8

ELECTRIC TRACING MERITS.....9

ELECTRIC TRACING LIMITATIONS.....9

STEAM TRACING MERITS ..... 9-10

STEAM TRACING LIMITATIONS .....10-11

TRACING SYSTEM ANALYSIS:.....11-14

    1. The Specific Application ..... 11

    2. The Tracing System Functional Performance..... 12

    3. The Tracing/Pipe System Energy Performance ..... 12

        • Insulation System .....12

        • Tracing Temperature Control.....12

        • The Heat Source..... 12, 13

    4. The Tracing System Installation Cost:.....13

        • Piping Complexity .....13

        • Temperature Maintenance/Control.....13

        • Area Classification .....13

**SUMMARY**.....14

Footnotes and References ..... 14



**THORNE & DERRICK** Thorne & Derrick  
**INTERNATIONAL** +44 (0) 191 490 1547  
[www.thorneandderrick.com](http://www.thorneandderrick.com)



# The Relative Merits and Limitations of Thermal Fluid, Electric and Steam Heat Tracing Systems

## INTRODUCTION

The cost of one heat tracing method versus another is of importance when selecting a heating system for plant pipes and equipment, given that each system has the capability to perform the required function. Today, however, long-term energy efficiency and the reduction of hydrocarbon pollutants may be the most important aspect in the selection of plant equipment including heat-tracing systems. Energy conservation and the reduction of greenhouse gas (GHG) emissions go hand-in-hand. As the use of energy increases, GHG emissions also increase. Today, most countries of the world have defined their energy and GHG emissions reduction goals. In the United States, a unified effort to combat excessive energy consumption and GHG emissions has resulted in a partnership between the Department of Energy (DOE) along with the Office of Industrial Technology (OIT) and U.S. industry. The partnership has focused on achieving three major objectives: (1) lowering raw material and depletable energy use per unit of output, (2) improving labor and capital productivity, and (3) reducing generation of wastes and pollutants.<sup>1</sup>

Industrial steam users contribute to an enormous amount of energy wastage in most countries. It is estimated that in the U.S. alone, roughly 2.8 quads (2,800 trillion Btu) of energy could be saved through cost-effective energy efficiency improvements in industrial steam systems.<sup>2</sup>

Steam is used in most plants to power turbines that turn generators for the production of electricity, as a prime mover for pumps and other equipment, and for process heat in heat exchangers and reactors.

Heat tracing systems are not often listed when energy reduction initiatives are being considered. However, when viewed from the perspective of how many meters (feet) of heat tracing exists in a typical refinery or chemical complex, the potential for reducing energy consumption and hydrocarbon pollutants can be startling.<sup>3</sup>

When discussing tracing systems, the question is often asked. "Which heat tracing system is the most economical; steam, electric or fluid?" M.A. Luke and 2

C.C. Miserles made the following statement about that subject in a 1977 article about tracing choices and it holds as true today as ever:

"There is no definite answer to the tracing-selection problem. Using recommendations based solely on industry-averaged or assumed parameters will more often than not misrepresent a particular situation. Relying on past analysis for major new

decisions may overlook recent developments or changing variables. Excluding judgment factors, like the ability of existing operating and maintenance personnel to understand and live with the system provided, may lead to disaster." 4

As the authors predicted, many new and important developments have been made in heat tracing technology since their article was published in 1977.

## HEAT TRACING METHODS

### History

Since the early 1900's steam tracing has been the primary means of keeping materials such as petroleum residues, tars and waxes flowing through pipelines and equipment in the petroleum and chemical processing industries. For temperatures that were higher than would be practical for steam tracing, fluid tracing with mineral oils was often used. Mineral oils could be used at temperatures up to as much as 316C (600F). Saturated steam at this temperature would require a pressure of 107.0 bar g (1,549 psig). 5

Following the Second World War, the petroleum and chemical industries grew, as many new products were developed to meet the wants and needs of a society that was just emerging from the great depression. Many of the raw materials for these new products had to be maintained at temperatures below 66C (150F) and held within a narrow temperature band to protect the quality of the end product. The "bare" steam tracing method of the time was frequently inadequate to meet these requirements. Heat transfer compounds were developed in the early 1950's but were intended as a means to increase, not reduce the heat transfer rate of steam tracers. Ambient changes alone were often too great to permit satisfactory control with a bare steam tracing system. Various methods were tried to reduce the amount of heat supplied by the bare tracer after the steam pressure/temperature was set at a practical minimum level. One was to suspend a bare tracer above the pipeline and attempt to maintain an air gap with spacer blocks. This system was problematic. The blocks were difficult to keep in place during assembly and thus were tedious and time consuming to install. They frequently slipped out of place in service because of the natural expansion and contraction of the tracer tube. This system was plagued with unpredictable heat transfer rates, hot spots, and high installation costs.



# The Relative Merits and Limitations of Thermal Fluid, Electric and Steam Heat Tracing Systems

During this era plant engineers were inclined to use fluid tracing methods (glycols and hot oils) where possible because of the ease of regulating fluid flow to maintain required temperatures although due to inadequate fittings, leaks frequently presented a problem. Electric resistance heating was also developed in the early years of the 20th century and some types were adapted for pipeline heating, but they had minimal use due to burn out failures caused by excessive sheath temperatures at high wattages.<sup>5</sup> Fittings and connections were also weak points in the system. In the 1950's experimentation began in earnest to develop more durable electric tracing methods that could be adapted to automatic temperature controls. These efforts brought about marked improvements and by the 1960's, electric tracing began to be accepted as a viable challenger to steam and fluid tracing methods for heating process plant piping and equipment.

heat transfer fluid. Depending upon the type of heater and the control scheme, packaged thermal fluid units may be provided with microprocessor-based controls for reliable, safe and accurate operation. Today's leak-proof tubing connectors eliminate costly and sometimes hazardous loss of fluid which makes semi-rigid tubing an ideal means of tracing with heat transfer fluids. Tube fittings may be manually or automatically welded where pressure ratings are in accordance with ANSI B31.1 calculations if required. Tubing can be easily formed for elbows and bends or shaped into hairpin loops for valves and pumps. Tracers with heat transfer compounds provide even temperature distribution along the pipeline even in cooling applications. Additionally, they allow the use of lower fluid temperatures (as opposed to bare tracing) for warm applications since the heat transfer coefficient is greatly improved. Figure 2 depicts a typical steam heated liquid tracing system.

## OVERVIEW: TODAY'S THERMAL FLUID SYSTEMS

Control methods for tracers using heat transfer fluids are much more sophisticated today than ever before. Figure 1 shows a microprocessor controller (Sterling, Inc. www.sterlco.com) with "fuzzy logic" providing high accuracy. A great variety of heat transfer fluids are available for high or low temperature requirements. Portable or stationary fluid heating or cooling units are available. For heating applications, electrical, steam or fuel-fired heaters are used to raise the temperature of the



Figure 1

Figure 2

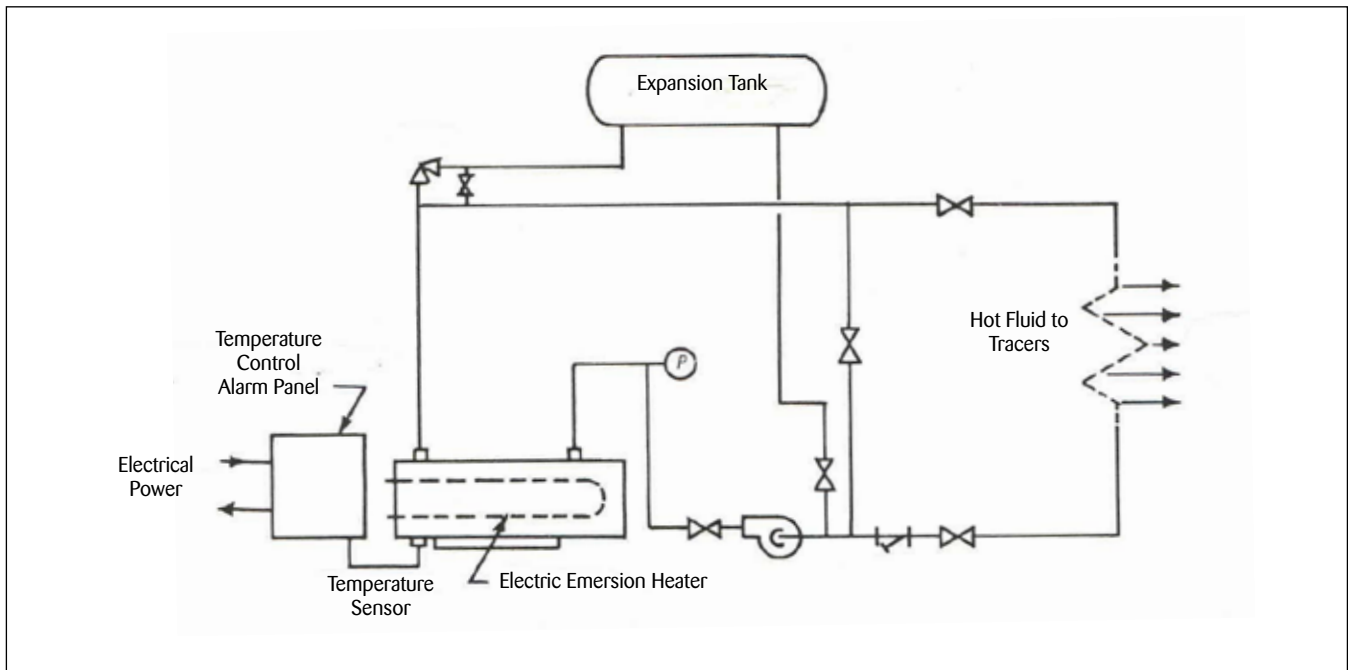



# The Relative Merits and Limitations of Thermal Fluid, Electric and Steam Heat Tracing Systems

## OVERVIEW:

### TODAY'S ELECTRIC TRACING SYSTEMS

Modern electric tracing systems have extremely low failure rates as opposed to the electric resistance heat tracing systems of the past, due to improved technology and industry standard requirements that must be met in order to be accepted as a viable supplier in this market place. Microprocessor based controls can hold pipe temperatures to extremely close tolerances. State of the art high temperatures polymers and processing methods have led to the development of new and improved flexible self-regulating and power limiting heating cables. These flexible heaters can be used to hold pipeline temperatures in the range of approximately 149C (300F) where steam, hot thermal fluids or copper sheathed mineral insulated heating cables would have been used in the past. The development of high temperature metal alloys has provided a means to increase the temperature maintenance rating of today's semi flexible mineral insulated electric heating cables up to as much as 500C (932F) with exposure temperatures up to 593C (1,100F). See Figure 3 and 4 for typical electric heat tracing system and microprocessor-based controller.



**Figure 4**

Microprocessor-based monitoring and control units for electric tracing systems – control band programmable in increment of 1 degree.

**Figure 3**

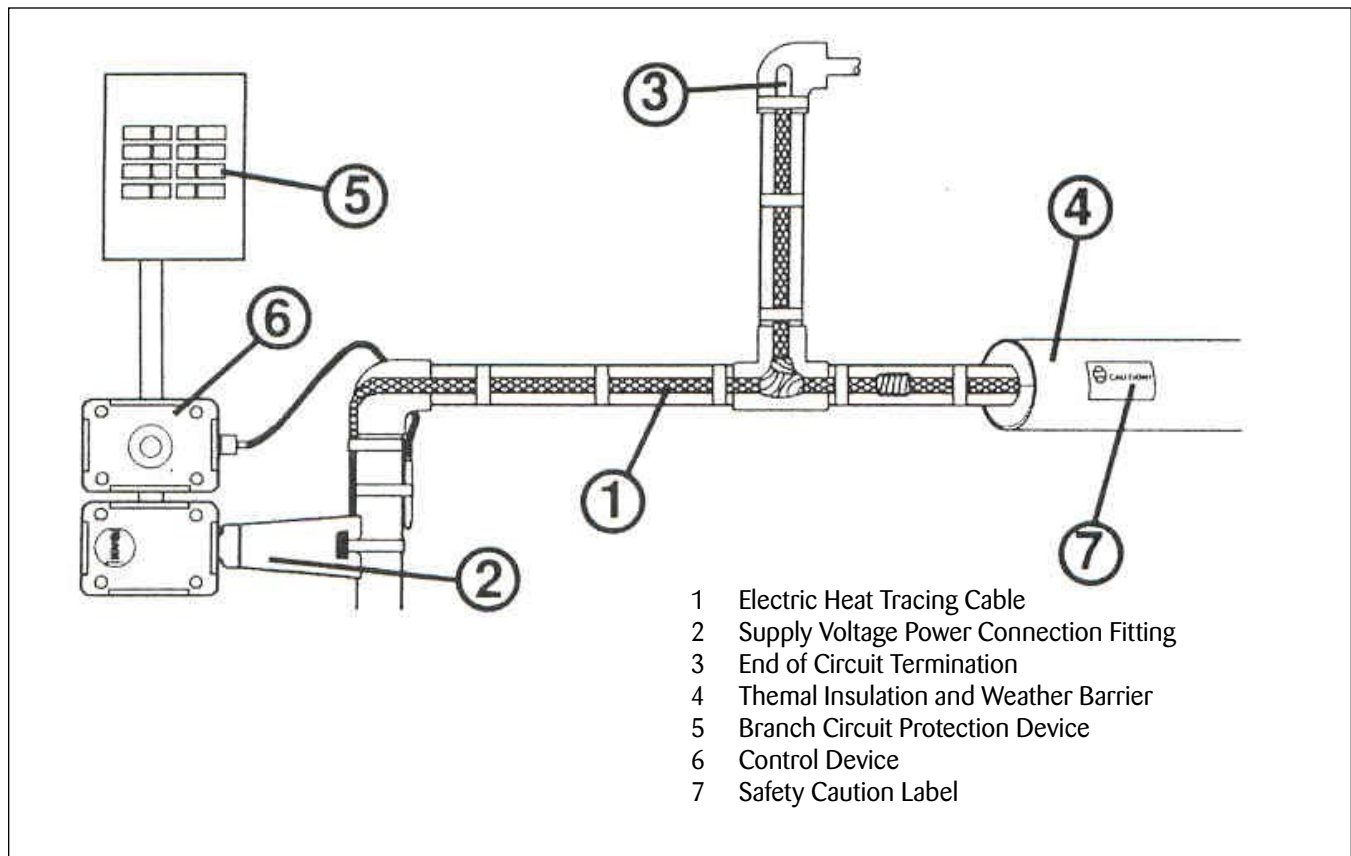



# The Relative Merits and Limitations of Thermal Fluid, Electric and Steam Heat Tracing Systems

## OVERVIEW:

### TODAY'S STEAM TRACING SYSTEMS

Today, a wide range of steam tracing methods exists. New factory fabricated isolated steam tracers have been developed that offer a range of heat transfer rates for low to medium temperature control as well as improved safety. Where low pressure steam is available, these tracers may be used to heat materials such as caustic soda, resins, acids, and water lines which previously could not be heated with bare steam tracing due to the excessive heat that could result in corrosion, vaporizing or "off-spec" products. Isolated tracers may also be used for temperature control where higher steam pressures are available rather than installing pressure reducing valves. For the high temperature range, steam may be used as the heat transfer medium in a modern "conduction" tracing system where heat transfer compound is installed over the tracer and

covered with a steel "Strap-On" Jacket to provide permanent and maximum contact at the surface of the pipeline. One conduction tracer will supply as much heat as 3 to 6 bare tracers and can supply heat up capability. Figure 5 portrays a typical steam tracing system. Most steam tracing is used in "run free" systems where no control methods are applied other than steam pressure reducing valves as shown in Figure 6. However, several control methods are available. Figures 7 and 8 details hookup methods for pipeline control and ambient sensing control. Figure 9 shows control by balanced pressure traps holding back condensate while Figure 10 depicts an isolated steam tracer that is used to lower the temperature of a traced pipeline versus a conventional bare tracer, by decreasing the heat transfer rate from the tracer to the pipe.

**Figure 5**  
**Typical Steam Tracing System**

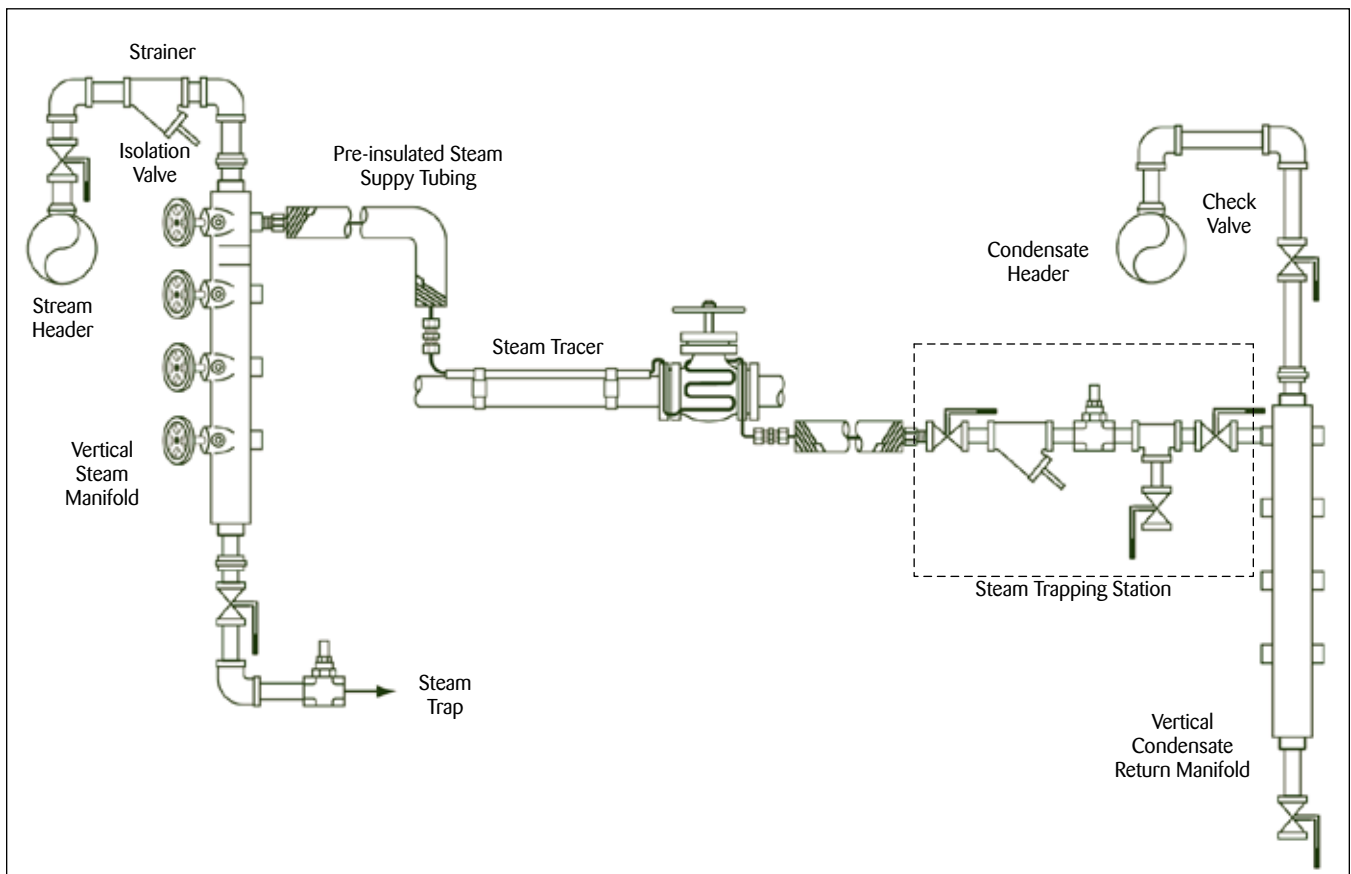



# The Relative Merits and Limitations of Thermal Fluid, Electric and Steam Heat Tracing Systems

**Figure 6**  
**Steam Pressure Reducing Valve (PRV) Station**

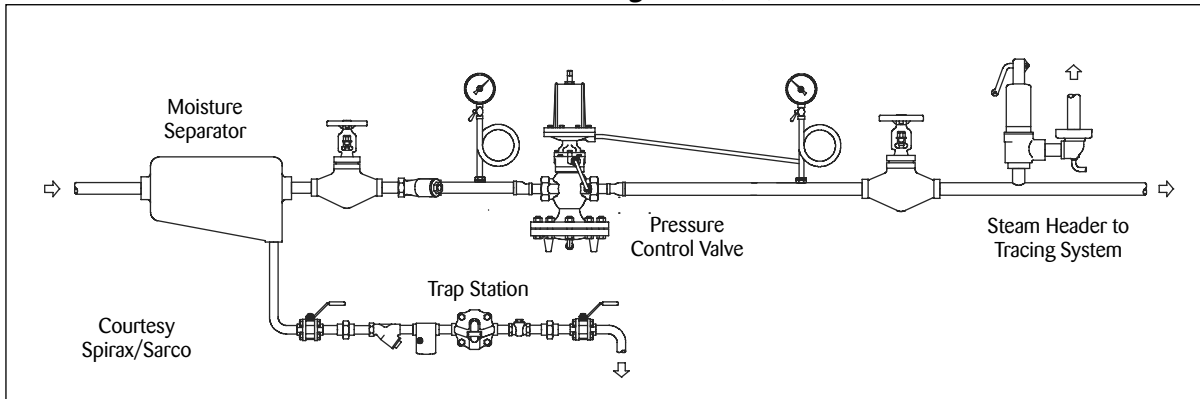

**Figure 7**  
**Tracing With Self-Acting Pipeline Sensing Control**

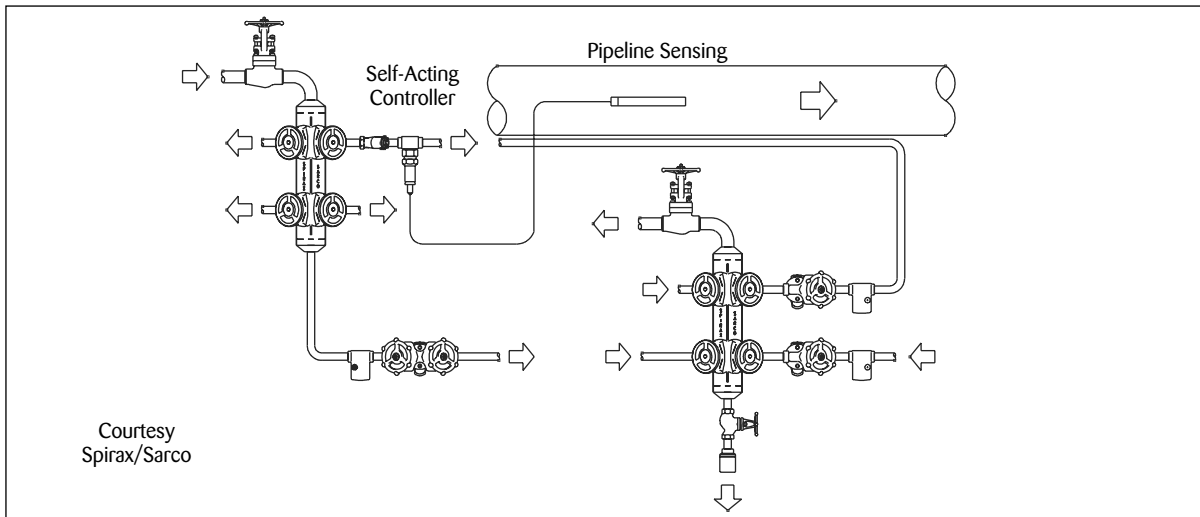

**Figure 8**  
**Tracing With Self-Acting Ambient Sensing Control**

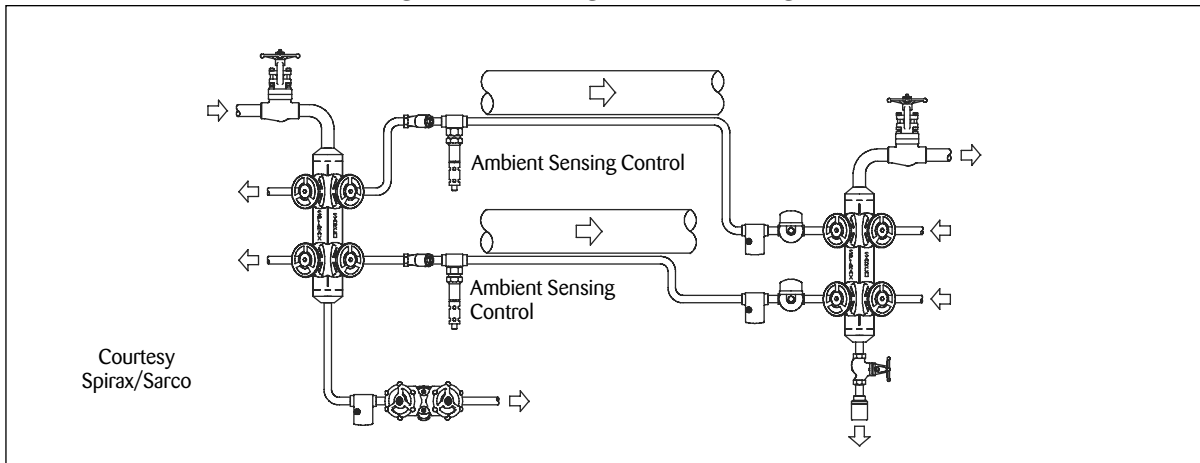



# The Relative Merits and Limitations of Thermal Fluid, Electric and Steam Heat Tracing Systems

Figure 9  
Control by Holding Back Condensate

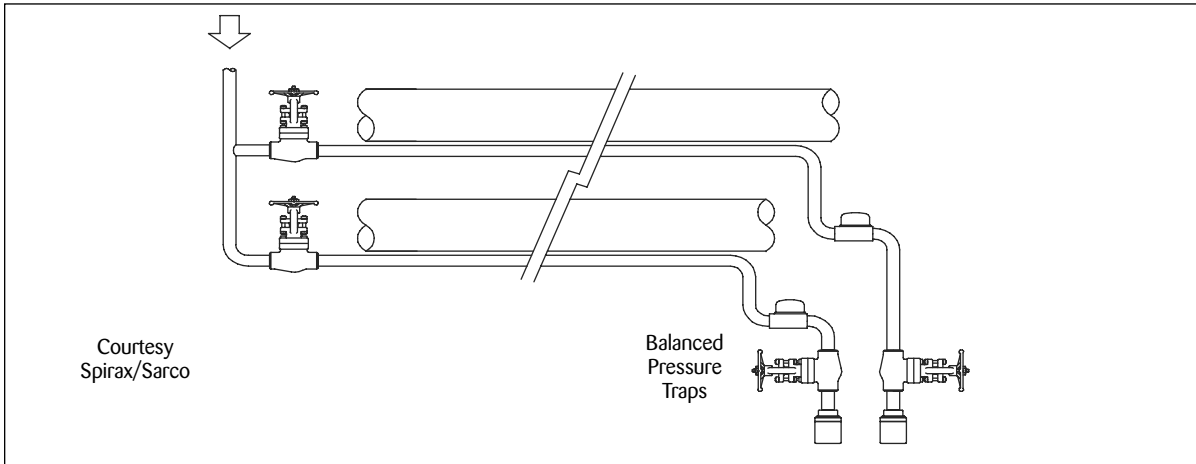

Courtesy Spirax/Sarco

Figure 10  
Isolated Steam Tracer for Temperature Control

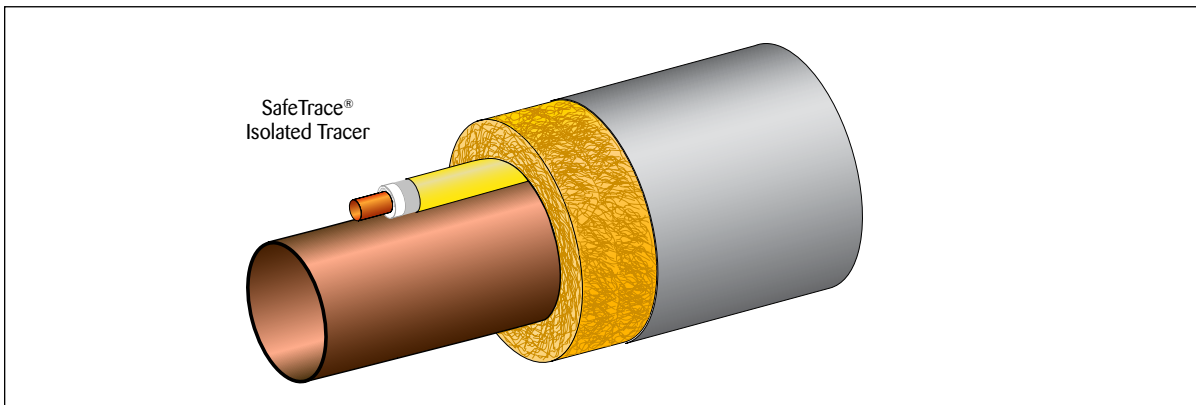

## OVERVIEW: FREE STEAM

Steam tracing circuits can frequently use flash steam from hot condensate, steam produced by waste heat boilers, or steam from exothermic processes. Energy from these sources is often referred to as “free steam.” However, flash vessels (see Fig. 11), waste heat recovery equipment and various accessories are required to control and transport this steam. The equipment and the attendant maintenance services are not free. But, additional fuel is not being consumed to produce this steam, therefore it is a low cost energy source and is often referred to as “free steam.”

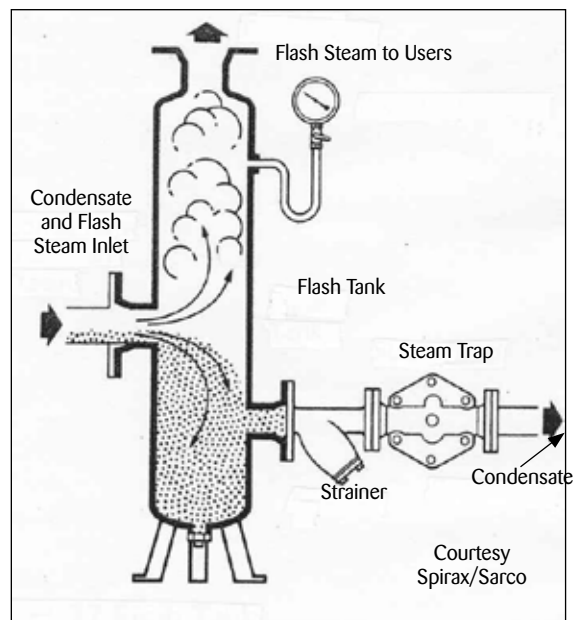



# The Relative Merits and Limitations of Thermal Fluid, Electric and Steam Heat Tracing Systems

## SOME BASIC COMPARISONS

The following outlines the relative merits and limitations of each system in various applications:

### THERMAL FLUID TRACING MERITS

- Today, a variety of thermal fluids are available to cover a wide range of heating or cooling applications. WATER is often used for low to medium temperature heating to its availability; thermal stability and heat transfer properties. AROMATICS may be used for temperatures in the 320°C to 400°C (608°F to 752°F); SILICONE-BASED FLUIDS may be used up to approximately 400°C (750°F) and for process cooling as well. HYDROCARBONS or mineral oils have been used for years and generally have a maximum operating of up to 321°C (610°F).<sup>6</sup>
- Thermal fluid tracing is good for applications requiring reasonably close temperature control. Generally heat transfer compounds are recommended for either heating or cooling since these materials provide an increased high heat transfer coefficient and positive contact between the fluid tracer and the process line being heated or cooled. The improved heat transfer rate and contact provides uniform temperature distribution throughout the pipeline.
- Thermal fluid tracing systems can be designed for utilization in hazardous areas.
- Most thermal fluids are less susceptible to freezing or bursting the tracer or handling equipment during shutdowns than with condensate from a steam tracing system when ambient temperatures are below -29°C (-20°F).
- An “ideal” thermal fluid possesses the following characteristics: <sup>6</sup>
  - Thermal Stability: There should be no significant change in chemical composition following repeated heating and cooling cycles.
  - Intrinsically Safe: It should not present an extreme fire or explosion hazard under normal operating conditions. Properties such as flashpoint and firepoint should be evaluated prior to selection. Most thermal fluids can be operated at temperatures above these temperatures because any leaks usually are of limited volume, which minimizes the potential for exposure to an ignition

source. A thermal fluid should never be operated above its atmospheric boiling point due to the potential for mist explosions around leaks.

- Chemically Safe: Incidental exposure should not be hazardous to operating personnel.
- Low Viscosity at Ambient Temperature: High viscosity fluids will be difficult on cold system startup.
- Low Vapor Pressure at Operating Temperature: Low vapor pressure eliminates the need to pressurize the entire system to prevent pump cavitation.
- Good Physical Properties: The heat transfer coefficient is directly proportional to the specific heat ( $C_p$ ), density ( $\rho$ ) and thermal conductivity ( $k$ ), and inversely proportional to the viscosity ( $\mu$ ).

### THERMAL FLUID TRACING LIMITATIONS

- Thermal fluids typically have a low heat capacity, especially when compared to steam tracing. Multiple fluid tracers may be required on a pipeline for the equivalent heat delivery of a steam tracing system.
- A thermal fluid tracing system requires multiple tracing circuits before it can be justified. The fluid handling units are made up of an expansion tank to provide space for fluid expansion and a net positive suction head for the pump; a circulating pump to keep the thermal fluid flowing; a heater to heat up the liquid to the required temperature and reheat it as it returns from the tracers, and a flow/temperature control method to maintain the required thermal fluid and process pipe temperatures.
- Flow restrictions in thermal fluid tracing systems limit the tracing circuit lengths compared to either a steam or electric tracing system.
- The impact that potential leaks or spills may have on the environment must be addressed with any thermal fluid tracing system. At elevated temperatures, hydrocarbon based fluids may become volatile if leaks occur in the system.
- Initial fluid cost and replacement cost should be considered since some fluids are very expensive:



# The Relative Merits and Limitations of Thermal Fluid, Electric and Steam Heat Tracing Systems

## ELECTRICAL TRACING MERITS

- Most industrial facilities will have electrical power available.
- A variety of types and methods of electric tracing may be used to maintain a broad range of temperatures for process pipes and associated equipment. Electric heat output can be adjusted for very low freeze protection applications to very high process maintenance temperatures up to 500C (932F) through heater selection and the use of design variables such as supply voltage.
- Short lengths of pipe or long pipelines in the range of 25 kilometers (15 miles) in length may be heated by the use of various types of heating cables or skin effect heat tracing systems.
- Electrical tracing is recommended for non-metal and lined piping and process equipment because of the ability to provide very low heat output.
- Electric tracing is often recommended for use with temperature sensitive products that must be maintained within a narrow temperature range. It is easily equipped with temperature control devices to maintain precise consistent temperatures to keep process temperatures within specification limits and to conserve energy.
- Since electric tracing does not convey a fluid, there are no fittings or traps that may cause energy leaks or require routine maintenance. This translates into simplified installation and reduced operation and maintenance costs.
- Over its history, electric tracing has proven to be a safe choice for process pipe and equipment heating. High industry standards and approval agency testing provides verification of fitness for the intended service.

## ELECTRIC TRACING LIMITATIONS

- If sized for temperature maintenance, electric heat tracing often provides an unacceptably slow heat-up period for the resumption of flow after an emergency shutdown or a plant turnaround.
- As previously discussed, electric tracing can be designed for safe operation in hazardous areas and has a sound track record in such applications but it does have the potential for sparking which could lead to fire or explosion anywhere flammable materials are present in the atmosphere surrounding the tracer.
- Electricity for tracing can cost considerably more per Btu than steam particularly if “flash” steam or steam from exothermic processes is available for steam tracing. If a plant has a cogeneration facility, a cost difference will still exist between electricity and steam but it will be much lower.

## STEAM TRACING MERITS

- Steam tracing is frequently chosen for use in plants where steam is a by-product of condensation (“flash” steam) or an exothermic process. In these cases, electricity will be much more costly than steam. Steam from these sources is often (incorrectly) considered to be “free steam” but as previously stated, it does have a small handling cost attached to it although additional fuel is not being consumed.
- Steam is excellent for heat-up situations because the highest rate of heat transfer occurs when the temperature difference between the steam tracing and the cooler piping or equipment is greatest. During heat-up, steam condenses fast, releasing a large amount of latent heat energy due to the big temperature difference between the cold piping, (or equipment) and the steam tracer. As the process equipment warms up, the gradual decrease in temperature difference brings about a corresponding decrease in the rate of steam condensation until an equilibrium condition is finally reached. The large latent heat content of steam makes it an excellent medium for start up situations following a plant turnaround or after an emergency shutdown. Pipelines that are intermittently used at tank terminals to transfer sulfur, asphalts, or other heavy hydrocarbon materials, rely on steam for quick heat up and temperature maintenance once the system has reached a state of equilibrium. In an equilibrium state, the heat supplied by the steam tracing system is equivalent to the heat being lost to the atmosphere through the thermal insulation material covering the tracer and the pipe.
- Steam tracing is intrinsically safe and may be used in Division 1 (and Zone 0) hazardous areas where electric tracing circuits are severely restricted (or prohibited) for safety reasons. API Publication 2216, Second Edition, January 1991 states the following: “The ignition of accidental releases of hydrocarbons in the atmosphere may result in damaging fires. Frequently, hot surfaces in the area where hydrocarbon vapor is released are assumed to be the ignition source; however, hot surfaces, even at temperatures above the published and generally accepted ignition temperature of the hydrocarbon, may not ignite the flammable mixture. ---As a rule of thumb, ignition by a hot surface in open air should not be assumed unless the surface temperature is about 200°C (360°F) above the accepted minimum ignition temperature.” Generally steam provided for tracing purposes will not exceed the above noted temperature limits for most hydrocarbons. Additionally, most steam supply lines today are covered with thermal insulation to reduce heat loss and to minimize personnel injuries by keeping the insulation



# The Relative Merits and Limitations of Thermal Fluid, Electric and Steam Heat Tracing Systems

surface at a maximum temperature of 60°C (140°F) or less for personnel protection.

- The temperature of steam tracing circuits can be controlled by:
  - Pressure reducing valves which vary the steam pressure and thus the steam temperature.
  - Isolated tracers which provide a low conductive path to reduce temperatures and conserve energy for lines carrying materials such as amine, caustic, resins, water, wastewater, or for holding pipeline temperatures with 10.3 barg to 17.2 barg (150 psig to 250 psig) steam without the need for pressure reducing valves that might be necessary for bare steam tracers in order to limit the heat output.
  - Self-acting control valves with sensors responding to the ambient air temperature or the process pipe temperature.
  - Fixed-temperature discharge steam traps or balanced pressure traps which respond to condensate temperature and allow condensate to sub cool within the tracer before being discharged.
  - Thermostatically controlled solenoid valves, which can provide an off-on operation. The thermostat serves only pilot duty, and off-on control provides the tracer circuit with the full benefit of the heating media during start-up.
- Condensate from steam tracing can be returned for re-heat and use at the boiler because it is considered “clean condensate”. However, condensate from heat exchangers and jacketed equipment is not considered clean due to the possibility of cross contamination with process fluids.
- Steam is simple and reliable. It is a constant energy source and flows under its own power. When steam condenses into saturated water in the tracer, it frees up a volumetric space, which is constantly filled with steam under pressure. This perpetual process keeps steam flowing as long as the system is in operation.

## STEAM TRACING LIMITATIONS

- Steam tracing is not generally recommended for use with non-metal or lined piping and vessels although modern isolated tracers may be applicable in some cases.
- Steam tracers require fittings, which have the potential to develop leaks. However, modern precision-made compression fittings can provide a leak proof connection when properly installed.

- Each cycle of an Inverted bucket trap or a thermodynamic type trap uses a certain amount of steam in order to perform its function. A steam loss also occurs in thermostatic traps due to a small lapse of time in the closing of the valve as the last remaining condensate exits and steam enters. Impulse traps have a continuous small amount of steam lost through the pilot orifice. Further, each trap has some radiation losses. The steam trap supplier should be able to provide the typical kg (lbs) steam loss per hour for the particular trap selected. One manufacturer states that the operational steam lost from steam traps is a maximum of 0.90 kg (2lbs).<sup>7</sup> For small steam tracer traps, the steam loss per hour is estimated to be in the range of 0.22 kg to 0.45 kg (0.5 lb to 1.0 lb).
- Steam headers and condensate return lines providing service to steam tracers will lose a certain amount of steam energy even when covered with thermal insulation. Steam supply and condensate return manifolds will also lose a certain amount of steam energy. However, energy losses may be minimized by the application of thermal insulation on steam lines and equipment.
- Malfunctioning steam traps can contribute to steam energy loss on steam-traced lines. One source states that “steam-trap failures on an ongoing basis of 3% to 10% will contribute to the flow of live steam in the return line<sup>8</sup>.” Another source states that “in systems with a regularly scheduled maintenance program, leaking traps should account for less than 5 percent of the trap population<sup>9</sup>.”



# The Relative Merits and Limitations of Thermal Fluid, Electric and Steam Heat Tracing Systems

The most common orifice size for steam traps servicing steam tracers is 3.0 mm for metric sized traps and 1/8" for inch-Pound sizes. Approximate steam losses for malfunctioning traps in tracer service are given in Table 1 and Table 2 below. A good maintenance program will help minimize energy losses from steam traps as described under NOTE below.

One major trap manufacturers estimates that, on average, each defective trap wastes over 400,000 pounds (approx. 180,000 kg) of steam a year.<sup>2</sup> If one chooses the 7.0 Bar g

**Table 1**

Approx. Energy Loss Due to Steam Trap Leaks kilograms/hr			
Trap Orifice Diameter mm	Steam Pressure Bar Gauge		
	3.5	7.0	10.0
2.0	5.0	8.8	12.0
3.0	<b>12.5</b>	<b>22.2</b>	<b>30.5</b>
5.0	31.0	55.1	75.4

**Table 2**

Approx. Energy Loss Due to Steam Trap Leaks pounds/hr			
Trap Orifice Diameter inches	Steam Pressure Bar Gauge		
	50	100	150
5/64	10.6	18.9	27.1
1/8	<b>27.2</b>	<b>48.3</b>	<b>69.3</b>
3/16	61.3	108.6	156.0

column and the 3.0 mm orifice size from Table 1 and considers 8400 hours per year to account for a two week turnaround time, the loss per trap will be  $22.2 \times 8400 = 186,480$  kg/yr ( $186,480 \times 2.2 = 410,256$  lb/yr).

From Table 2 choose the 100-psig column and the 1/8" orifice, the loss will be  $48.3 \times 8400 = 405,720$  lb/yr. steam wasted annually. Therefore, the statement from the trap manufacturer provides a realistic value.

Steam trap monitoring systems are available from most major trap manufacturers and can help reduce steam losses due to malfunctioning traps if installed and implemented properly. Regular continuous monitoring will identify malfunctions such as leaking or condensate back up.

## TRACING SYSTEM ANALYSIS

A complete tracing system analysis should consider all of the following:

- The specific application
- The tracing system's functional performance
- The tracing/pipe system energy performance
- The tracing system's installation cost.

### 1. The Specific Application

Typical Information Required to Begin an Assessment.

- Plant/Location
- Climatological Data:
  - Minimum Ambient Temperatures
  - Maximum Ambient Temperatures
  - Annual Average Ambient Conditions
- Process, Utilities or Service Materials to be Heated
  - Properties
  - Specifications
  - Processing Hours
  - Heat Up Requirement
  - Flow Path of Process Fluids
- Temperature Control of Product and Monitoring Requirements
- Energy: Location; Type; Quantity; Quality; Cost
  - Area Classification
  - Electric Energy Cost
  - Voltage
  - Steam Energy Cost
  - Steam Pressure
  - Heat Transfer Fluid Cost Including Packaged Heater Unit
- Piping: Materials; Lengths; Sizes; and Grade Level
  - P & ID's 17
  - Piping Isometrics
  - Piping Line List; Etc.
- Insulation: Type, Thickness and Weather Barrier
- Labor: Rates and Maintenance Hours Required
- Tracing System Alternatives Under Consideration

### 2. The Tracing Systems Functional Performance

First and foremost, any tracing method considered must be able to meet the functional requirements of the process piping and equipment being traced. The tracing system must heat-up and maintain the piping system at the prescribed temperature. A heat up time requirement may be placed on the system not only for the initial start up but start-ups following a turnaround or emergency shut down. The pipe, product, heater, and insulation maximum temperature limitations must



# The Relative Merits and Limitations of Thermal Fluid, Electric and Steam Heat Tracing Systems

not be exceeded under normal and abnormal conditions. The temperature control system, if one is necessary, must provide the required accuracy of control. A temperature alarm system may also be required to fulfill safety or production specifications. Operations may require monitoring of the heating system. These considerations are all necessary to arrive at a functional system.

### 3. The Tracing/Pipe System Performance

The energy consumption characteristics of a tracing system are primarily a function of the following:

- Insulation System
- Type of Tracing System Temperature Control
- Type of Heat Source

#### The Insulation System

A heat tracing system in the most common application (temperature maintenance) is designed to replace only that heat which is lost through the thermal insulation. The energy consumption is directly related to the energy loss characteristics of the insulant, which is a function of the insulation type and thickness. While heat loss reduction and optimization is possible by prudent selection of the insulation type, it should be understood that the insulation type must be matched to the functional requirements of the application, i.e. minimum temperature limits, water resistance, tensile and compressive strength, flammability, etc. The heat loss reduction optimization should then be based on Insulation thickness. The optimum insulation thickness is established by estimating the following costs for a given insulation thickness:

- The annualized cost of the insulation system including installation and maintenance
- The annualized cost of the energy lost.

The optimum insulation thickness is that thickness for which the sum of these costs is a minimum.

#### Annualized Insulation and Energy Cost Via the Use of 3E Plus®

The Insulation thickness can be established via the use of 3E Plus, a Insulation thickness computer program that can be downloaded FREE from [www.pipeinsulation.org](http://www.pipeinsulation.org) It is designed for Facility Managers, Energy and Environmental Managers and Industrial Process Engineers.

#### The 3E Plus Program:

- Calculates the thermal performance of both insulated and un-insulated piping and equipment
- Translates Btu losses to actual dollars

- Calculates greenhouse gas emissions and reductions
- Used as a tool in several DOE programs

3E Plus simplifies the task of determining how much insulation is necessary to use less fuel, reduce plant emissions and improve process efficiency. The information described herein is from the INSULATION OUTLOOK MAGAZINE, December 2002 at [www.insulation.org](http://www.insulation.org).

#### Tracing Temperature Control

When there is no material flowing in a piping system, a pipe temperature-sensing controller, which activates and deactivates the tracing system, reduces energy consumption by permitting the tracer to deliver only that energy which is required to maintain the pipe temperature. When flow occurs in the pipe at temperatures above the controller set point, the pipe-sensing controller de-energizes the tracing and minimizes energy consumption. Tracing controllers, which sense ambient temperature rather than pipe temperature, are less energy conservative since these controllers permit continuous energizing of the tracing when the ambient temperature is below the controller set point. The result is higher energy consumption by the tracing. Although control methods are available for steam tracing systems, they are not widely applied due to user indifference.

#### The Heat Source

- The energy consumption of parallel and series resistance electric tracers is limited to the Joulian ( $I^2R$ ) heating ability of the cable. Most plants will have electricity available for electric tracing either purchased or produced at the plant site (cogeneration).
- Steam tracers are a constant temperature heat source. Their energy consumption is proportional to the steam temperature minus pipe temperature differential. When control schemes are not employed energy consumption of a steam tracer increases when the process fluid temperature is less than the equilibrium temperature flowing through the process pipe.
- A thermal fluid tracing system requires multiple tracing circuits before it can be justified due to the cost of the fluid handling unit. The fluid handling units are made up of 1) an expansion tank to provide space for fluid expansion and a net positive suction head for the pump; 2) a circulating pump to keep the hot fluid flowing; 3) a heater to heat up the liquid to the required temperature and reheat it as it returns from the tracers. Process temperature control can be accomplished via flow control valves for multiple users or by a process temperature sensor that controls the heater for single users. Thermal fluid heaters are either fuel fired,



# The Relative Merits and Limitations of Thermal Fluid, Electric and Steam Heat Tracing Systems

steam heated or heated via electrical resistance heaters. The total installation cost, energy costs and the intended operating pattern should be considered when selecting the type of heater for the system.<sup>6</sup>

## 4. The Tracing System Installation Cost

The installation costs of steam, fluid and electric tracing are a strong function of:

- Piping Complexity
- Temperature Maintenance/Control Monitoring
- Area Classification

### Piping Complexity

Electric tracing cables are normally more flexible than tubing and thus installation time is less for regular objects such as valves, pumps, filters, elbows, flanges, etc. As a tradeoff, however, the number of electric circuits and controllers will increase as the complexity increases and will thus increase the cost of an electric tracing comparison to an uncontrolled steam tracer.

### Temperature Maintenance/Control Monitoring

The installation of pipe sensing temperature control/monitoring can be as simple as an indicating on/off mechanical thermostat or it can be as sophisticated as a microprocessor based control package. In the case of steam tracing, control and monitoring devices are available but are seldom used. The relative costs of steam, electric or thermal fluid tracing systems are related to some degree by the control/monitoring applied to each system. Steam tracing efficiency will depend in large measure on keeping malfunctioning steam trap energy losses at a minimum.

With the use of the control systems mentioned above electric tracing circuits can hold pipe temperatures at 5°C (40°F) for freeze protection by the use of simple preset controls, or adjustable control thermostats for freeze protection and temperature maintenance. Microprocessor-based temperature control and monitoring units for single, dual or multiple circuits can provide temperature control up to 500°C (932°F).

Thermal fluid tracing systems can hold very close temperatures for low or high temperature applications and may be controlled by control valves and/or microprocessor-based control systems. Certain thermal fluids may be used in a temperature range of 260°C to 400°C (500°F to 750°F) which is beyond the range of temperatures normally associated with steam tracing. Electric tracing (Alloy 825 mineral insulated heaters) may show

to advantage on individual piping circuits at these temperatures due to the cost of a thermal fluid heating unit.

Steam tracing is generally associated with high heat delivery for applications where steam in the pressure range of 3 barg to 21 barg (50 to 300 psig) is used. However, new isolated tracers have been designed to provide a steam tracing method for low to medium heat delivery to hold pipeline temperatures from 5°C (40°F) to 93°C (200°F). These tracers are used for many applications where soft heat is required for materials such as caustic soda, resins, amine, etc. Control methods include ambient sensing, pipe sensing, condensate controlling traps and isolated tracers. However, where very tight temperature differentials are required, electric tracing or thermal fluid tracing methods are generally the best choice. In high heat delivery applications, fluid tracing and electric tracing may require multiple passes. As a result, steam tracing will normally have a more favorable relative installed cost when higher heat load and quick heat up applications are considered.

### Area Classification

In hazardous areas, watt per foot outputs may be limited in order to comply with runaway temperature restrictions. Again, this may result in multiple passes of heater cable and which will result in increased installation costs. A constant temperature heater such as steam generally does not fall under the jurisdiction of these runaway temperature restrictions as previously described and thus will enjoy the installation cost benefit resulting from installing fewer passes of tracer.



# The Relative Merits and Limitations of Thermal Fluid, Electric and Steam Heat Tracing Systems

## SUMMARY

It is important to understand that there is no one single heat-tracing method that is best for every situation. The specific application under consideration with its particular requirements should be the determining factor as to which heat tracing method to employ.

In fact there are situations where one, two or all three of the methods described herein may be used to economic advantage in an industrial plant. Steam may be available and the best choice for tracing in one unit while electric or fluid is the best choice in another. Most large refining and chemical facilities will generally have steam and electric tracing in use throughout the plant. The textile industry will often have steam and thermal fluid heating systems for higher temperatures.

The heat tracing decision can be made easy for users who do not already have a steam source available. It is doubtful that anyone would invest in a steam boiler for heat tracing only. On the other hand, where steam is being used in a facility for other purposes there may be surplus steam available that must be either used or lost. In this case, the incentive to use steam tracing or a steam fired fluid heater for liquid-tracing purposes will be compelling.

One manufacturer of external heat tracing systems ([www.thermon.com](http://www.thermon.com)) has had direct experience with steam, electric and fluid tracing design, supply and installation for almost 50 years. The knowledge gained in the science of external heat transfer through field applications and the company's testing facilities has been assembled and the data programmed into a comprehensive computer analysis package called AESOP for Advanced Electric and Steam Optimization Program. Today, an optimum tracing system for a particular facility under evaluation can be expediently selected regardless of the degree of complexity.

## Footnotes and References

1. Arlene Anderson, "Industries of the Future-Reducing Greenhouse Emissions," EM Magazine, March 1999, pp. 13.
2. Ted Jones, "Gathering Steam," Insulation Outlook, March 1998.
3. Knox Pitzer, and Roy Barth, "Steam Tracing for Energy Conservation." Chemical Engineering Exposition and Conference, June 7-8, 2000.
4. M. A. Luke and C. C. Miserles, "How Steam and Tracing Compare in Plant Operation," Oil and Gas Journal, November 7, 1977, pp. 64-73.
5. Thomas K. McCranie, "Heating Oils and Other Fluids in Cement Plants," Presented at the 1972 IEEE Cement Industry Technical Conference.
6. Jim Oetinger, "Using Thermal Fluids For Indirect Heating," Process Heating Magazine, October 1997.
7. Ted Boynton, and Bob Dewhirst, "Energy Conservation Thru Trap Surveys and Preventive Maintenance Programs," Armstrong International.
8. Mackay, Bruce, P.E., "Designing a Cost-Effective Condensate-Return System." Chemical Processing, May 1997.
9. "Insulation Outlook Magazine." April 2002. Published with this footnote: "Adapted from an Energy TIPS fact sheet that was originally published by the Industrial Energy Extension Service of Georgia Tech."
10. Custom Marketing Report for Thermon Manufacturing Company, Saunders Management Associates, September 1994.
11. Roy E. Barth and Arthur McDonald, "An Energy and Cost Evaluation Of Electric & Steam Tracing For Refineries, Inc Oil-town, USA." 1994. Note: Much of this work was incorporated in the section "Tracing System Analysis."



THORNE &  
DERRICK  
INTERNATIONAL

Thorne & Derrick  
+44 (0) 191 490 1547  
[www.thorneandderrick.com](http://www.thorneandderrick.com)