



CONTENTS



Kingsmill Industries (UK) Ltd is a leading manufacturer and distributor of earthing and lightning protection products for the UK and export markets.

The company aims to provide the highest standards of service and customer care without compromising quality or price. Undeniably, quality assurance is of paramount importance to the company and, to ensure this, all products are manufactured in accordance with BS EN 62305, BS EN 50164 and BS 7430.

Kingsmill Industries (UK) Ltd is an ISO 9001:2008 registered company.



CERTIFICATE No. 7077
ISO 9001 : 2008

ENQUIRY DETAILS	PAGE ii	CONDUCTORS	PAGE 34 - 48
COMPANY BACKGROUND	PAGE iii	FIXING CLIPS	PAGE 49 - 52
COMMITMENT TO STANDARDS	PAGE iv	CONDUCTOR NETWORK	PAGE 53 - 58
TECHNICAL BACKGROUND	PAGE v - vi	AIR TERMINATION	PAGE 59 - 61
KINGSMILL PROJECTS	PAGE vii	COMPRESSION CONNECTORS	PAGE 62 - 64
EARTHING	PAGE 1 - 6	ACCESSORIES	PAGE 65 - 66
SOIL CONDITIONING AGENT	PAGE 7 - 9	EXOTHERMIC WELDING	PAGE 67 - 68
INSPECTION PITS	PAGE 10 - 12	SURGE PROTECTION	PAGE 69 - 77
EARTH ROD SEAL	PAGE 13	STATIC CONTROL	PAGE 78 - 80
EARTHING PLATES & MATS	PAGE 14	EARLY STREAMER EMISSION DEVICES	PAGE 81
EARTH ROD CLAMPS	PAGE 15 - 17	BULK MATERIALS	PAGE 82
EARTH BONDS & CLAMPS	PAGE 18 - 23	QUALITY CONTROL	PAGE 83
EARTH BARS	PAGE 24 - 31	PART NUMBER INDEX	PAGE 84 - 85
FASTENERS & FIXINGS	PAGE 32 - 33	COMPANY LOCATION	PAGE 86
		COMMITMENT TO SERVICE	PAGE 87



**THORNE &
DERRICK
INTERNATIONAL**



PRODUCT CATALOGUE EDITION 6

Manufacturers and Distributors of Earthing & Lightning Protection Products.

All our high quality products are made in accordance with the relevant national standards including BS EN 50164 & BS 7430.

For further information or to place an order please contact our sales office:

Address:

4 Plymouth Avenue, Pinxton, Derbyshire, NG16 6NS, UK

UK Enquiries:

Telephone: 01773 510001 Fax: 01773 863336

E-Mail: sales@kingsmillearthing.co.uk

Web: www.kingsmillearthing.co.uk

International Enquiries:

Telephone: +44 (0) 1773 510001 Fax: +44 (0) 1773 863336

E-Mail: sales@kingsmillearthing.co.uk

Web: www.kingsmillearthing.co.uk

Dubai Office:

Ravco International General Trading LLC

P O BOX 42645, Dubai, UAE

Telephone: +97142677348 Fax: +97142677349

E-Mail: sales@ravcodubai.com



**THORNE &
DERRICK
INTERNATIONAL**

www.thorneandderrick.com

**KINGSMILL
INDUSTRIES (UK) LTD**

COMPANY BACKGROUND

Kingsmill Industries (UK) Ltd . . .

Kingsmill Industries (UK) Ltd have already become a leading manufacturer and distributor of earthing and lightning protection products for the UK and export markets and we have now been established for 13 years.

The company aims to provide the highest standards of service and customer care without compromising quality or price. Undeniably, quality assurance is of paramount importance to the company and, to ensure this, all products are designed and manufactured to meet stringent British and International standards - including BS 62305, BS 50164, BS 7430 and UL467.

In addition we have achieved the UK governments full BS 9001: 2008 National Accreditation in recognition of the high quality of our management systems and products. Kingsmill Industries (UK) Ltd is intrinsically sensitive to the needs of its customers and to the requirements of an ever-changing technological world.

Introduction to the catalogue . . .

This catalogue has been designed to meet the following specification:
 To provide as much relevant information about each product as possible.
 To enable products to be easily identified, located and referenced.

To help find the product you require, there is a part number index as well as a standard contents page. Products featured have technical and application drawings to ensure the correct product is related to the correct application.

See the page diagram below that displays the page format and the way in which the catalogue has been designed to provide easily accessed product data and information:

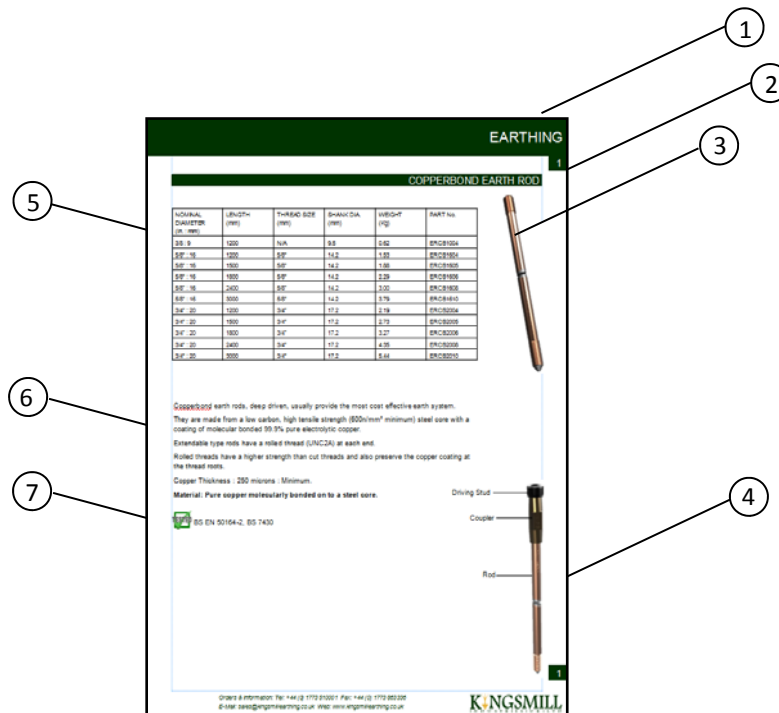

1. Chapter Heading.
2. Product Name.
3. Product Drawing / Image.
4. Product Application Drawing.
5. Data Table including dimensions and weights etc.
6. Product Information.
7. Information regarding the standard - See page iv for further information.

COMMITMENT TO STANDARDS

Commitment to Standards:

BS6551 has now been replaced with a combination of new standards based on the recently introduced CENELEC (European) standards. BSEN 62305 protection against lightning is substantially larger than its predecessor and has been written and compiled by experts from around the world. Containing some 475 pages it is more complex and covers a wider range of issues.

Structure of the New Standard:

BSEN 62305 is a series of publications in four parts, all of which have to be taken into consideration when designing for lightning protection.

BSEN 6230 (Part 1) General Principles. This is an introduction to the other parts of the standard and covers the General principles involved in the design. The sources and types of damage that need to be evaluated are clarified together with the types of loss/ risk that are possible due to lightning. It defines the relationship between damage and loss that are the basis for the risk assessment calculations in part 2 and also introduces the concepts Lightning Protection Zones (LPZs) and separation distances used when preparing a lightning protection scheme. The definitions of lightning current parameters are also provided and these used in selection and implementation of protection measures as detailed in parts 3 and 4.

BSEN 62305-2 (Part 2) Risk Management. This is significantly more detailed than in previous standards and details the process for determining the risk of lightning damage to structures and their contents. The results of the risk assessment determine the level of Lightning Protection System (LPS), both internal and external, required.

BSEN 62305-3 (Part 3) Physical Damage to Structures and Life Hazard. This part of the new standard relates most closely with BS6651 and deals with the protection measures to be used in and around a structure. It gives guidance on the design of both internal and external Lightning Protection Systems. An external LPS consists of an Air Termination System, a Down Conductor System and an Earth Termination System the parts of which require to be connected by components complying with BS EN 50164 series. The Kingsmill range of products are tested by Independent testing facilities and comply with the BS-EN 50164 series of standard for the manufacture of lightning protection components. BS EN 62305-4 (Part 4) Electrical and Electronic Systems within Structures. This standard covers the protection of electrical and electronic systems within structures. Using the concept of Lightning Protection Zones (LPZs) it covers the design, installation, maintenance and testing of an LEMP – Lightning Magnetic Impulse Protection system within a structure.

Lightning Protection Components:

Previous standards for Lightning Protection recommended the use of specific materials for lightning protection components. Now with the release of BS EN 50164 series of standards the focus is on performance and testing. This standard consists of the following parts.

- BS EN 50164-1:2008 Lightning Protection Components – Requirement for Connection Components
- BS EN 50164-2:2008 Lightning Protection Components – Requirement for Conductors and Earth

Electrodes

- BS EN 50164-3:2008 Lightning Protection Components – Requirement for Isolating Spark Gaps
- BS EN 50164-4:2008 Lightning Protection Components – Requirement for Conductor Fasteners
- BS EN 50164-5:2008 Lightning Protection Components – Requirement for Earth Electrode Inspection

Housing and Earth Electrode Seals

- BS EN 50164-6:2008 Lightning Protection Components – Requirement for Lightning Strike Counters
- BS EN 50164-7:2008 Lightning Protection Components – Requirement for Earth Enhancing Compounds

Kingsmill Lightning Protection Components are tested by The Research and Test Centre - High Voltage and High Current Testing Centre Laboratory – an RvA certified test laboratory. A full test report with certification is produced for all components satisfying the test criteria.



This symbol within the catalogue shows details of the relevant standards to which Kingsmill Lightning Protection Components are tested.



THORNE &
DERRICK
INTERNATIONAL

TECHNICAL BACKGROUND

Earthing:

The various standards for earthing provide design limits to be met and together with codes of practice explain how the earthing system can be designed to meet these. There are differences in the design limits applying to consumer installations and to supply industry installations and reference should be made to the correct standard to check the limits which apply in each situation.

In the past, it was normal practice to design an earthing system to achieve a certain impedance value. The earth electrodes being positioned near the equipment where a fault current was expected to pass. Recently, this has changed towards the approach used in North America. The most important difference is that the earthing system is designed to ensure that potentials in its vicinity are below appropriate limits. These potentials are referred to as:

- i) Step Potential (the potential difference between two points on the surface of the soil which are 1m apart).
- ii) Touch Potential (the potential difference during fault conditions between exposed metalwork and a point on the soil surface).
- iii) Transfer Potential (the potential difference between an insulated cable connected to a remote earth reference and the earth rod).

A number of factors will determine whether or not a person experiencing any of these potentials will be at risk, and the standards attempt to take these into account to ascertain the limits below which the design will be considered acceptable.

Lightning Protection:

If an unprotected building were to be struck by lightning the result may be fire, structural damage, damage to the electrical systems / equipment and electric shock. The purpose of a lightning protection scheme is to shield a building, its occupants and contents from these adverse effects. To do this properly the lightning protection system must capture the lightning, lead it safely down to earth, and disperse the energy within the ground. Whether or not a building needs a lightning protection scheme depends on several factors. The code of practice for Protection of Structures against lightning details and these are used to estimate risk. The risk assessment takes in to account the following factors:



Soil resistivity, the external dimensions of the structure including any adjacent structures that are electrically connected. The flash density (in thunderstorm days per year) for the area. The type of construction. Height above sea level and proximity of other structure such as tall trees. The length of any overhead cables entering the structure.

In the ensuing calculation, if the risk is found to be less than 1:100,000 then no protection is generally required. However this needs to be assessed in relation to the consequences of a direct strike. For instance, if the building is an explosive store then the highest level of protection will be required even if the risk of a strike is low.

Elements of a Lightning Protection System:

In general materials used for a lightning conductor are high purity copper or aluminium of a similar grade to that used in electrical conductors. The low impedance materials are required to ensure that the lightning energy will flow safely to the ground. The principal parts are detailed below.

Air Termination:

This is made up of vertical air terminals and / or a lattice of conductors on the roof and edges of the structure. Since no part of the roof should be more than 5m from the nearest horizontal conductor, a 10m x 20m lattice is generally used on large buildings. Traditional taper-pointed air terminals are not as frequently used today but when they are they should be positioned near those points where a strike is most likely to hit the building.



Down Conductors:

The purpose of the down conductor is to provide the low impedance path from the air termination system to the earth system. There is typically one down conductor for every 20m or part thereof the building perimeter at roof or ground level. If the building is above 20m or part thereof the building perimeter at roof or ground level. If the building is above 20m in height or of an abnormal risk this distance should be reduced to 10m. Any good conductor which forms part of the building structure can be employed as a down conductor with appropriate connection to the air termination and earthing systems. For down leads not part of the structure, copper and aluminium are the most widely used materials. These are sometimes PVC sheathed for aesthetic purposes only. Where practical they should be routed directly from the air termination to the earth system and be spaced symmetrically around the outside walls of the structure. At all times consideration must be given to the possibility of side flashing. Each down conductor should also be provided with a test point as a means of isolating the earth electrode for test purposes.



**THORNE &
DERRICK
INTERNATIONAL**

www.thorneandderrick.com

TECHNICAL BACKGROUND

Earth Termination:

Each down conductor must have its own earth electrode termination and the resistance to earth of the whole system must not be greater than 10 Ohms without taking into account bonding to other services. The most common terminations are rods driven into the ground. These should be a minimum of 9m for the whole system.

The individual earth electrodes are sometimes interconnected by a 'ring conductor' to help reduce the overall resistance. This should be at least 0.6m below ground level and preferably pass below incoming services. The ring conductor is made from copper tape or cable (aluminium is not permitted for use below ground) and also helps to provide potential equalisation at ground level, in addition to potential grading.

The earth system should be designed as a whole since the complete installation should rise in potential together, to avoid excessive voltage differences. For this reason, the earth termination should be bonded to the rest of the earth electrodes. Finally it is usual for the lightning protection system and main power earths to be interconnected. However, where this is not desirable for technical reasons, an earth potential equaliser can be installed between them. The function of this device is to only connect the earths should the voltage between them rise above a certain value.

Bonding:

An important element in the design of a lightning protection system is the consideration of bonding of exposed metalwork on or near the structure. This is to ensure that side flashing does not occur.

If exposed metalwork such as pipes or ducts etc. were not bonded to the system then, when a current flows in the down conductor creating a potential, the metalwork could be initially at a potential nearer that of earth. There would therefore be a potential difference between them. If this potential difference was greater than the breakdown value of the air or material in between, then a side flash could occur resulting in severe damage.

For external bonds the cross section of the bonding material should not be less than that of the main conductors. Internal bonds can however be of smaller cross section since they are mainly for equipotential purposes and are unlikely to carry a proportion of the lightning current.

MANUFACTURING TO CUSTOMER SPECIFICATION

Manufacturing to Customer Specification:

Using the combination of machinery and skilled staff, Kingsmill can in many cases produce bespoke products.

When an enquiry is made, it is usual for a drawing to be provided for the customer and confirmed with our engineering staff that the potential job is feasible. In some cases, advice is provided where necessary to the customer on the feasibility of certain jobs, or general advice on how the product would be best manufactured.

Here is an example of a drawing that was produced for a bespoke product enquiry:

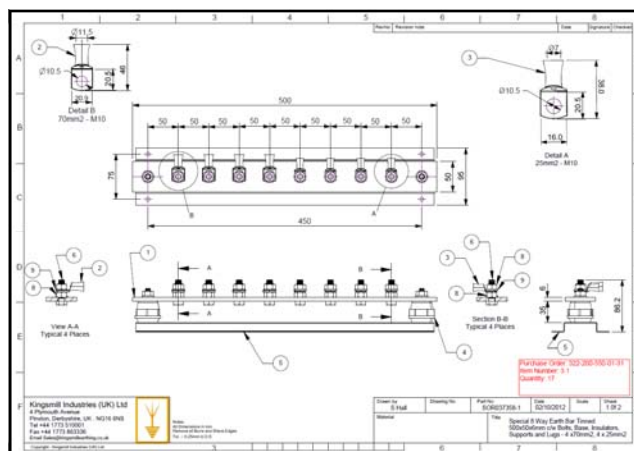

This helps to ensure that the customer is completely satisfied with the product that will be manufactured for them which enables to create an efficient delivery time and ensure that there is complete cohesion with the customer. All products are designed and manufactured to meet British & International standards including BS EN 62305, BS EN 50164 and BS7430 .



KINGSMILL PROJECTS

Kingsmill Projects:



The Jessops Monument was built in the 1850's in memory of William Jessop II who died in 1852. It cost £700 and was financed by voluntary subscriptions. The tower, a grade II listed building is 90ft tall and has 150 steps in a spiral staircase leading to a viewing platform at the top. In July 1861, it was struck by lightning that caused substantial damage to the block-working with a zig-zag scar running from the top to the bottom of the building. The building was left in a state of dis-repair for many years. During 2007, it has been fully restored and Kingsmill Industries (UK) Ltd are proud to be involved in this project by supplying the new lightning protection system materials at no cost.



Kingsmill Projects:

As well as supplying UK mainland, Kingsmill industries (UK) Ltd supplies products to international projects.



Pallets of Bare Copper Tape being prepared for export.

Many other national and international projects include;

The New Wembley Stadium, London, University of Cork, Ireland, Sheraton Hotel, Syria, Railtrack PLC, Stormont Castle, The Houses of Parliament, University Of Cork, West Ham Football Club, Waterfront Hall Belfast, Chahabar Shopping Mall Iran, Kuwait Gulf Investment Building, Maltacom, Woolwich Barracks, Eddystone Lighthouse, Harrods Department Store, Orange Telecom, Norvartis Chemicals, Bombardier Rail, Royal Air Force Lakenheath, Mount Vernon Hospital, Fujairah Water & Power, Festival City UAE,

St. Josephs Hospital Beirut, PTC Yemen, Lonestar Communications, Beachyhead Lighthouse, Vodaphone Telecommunications, Barbican Arts Centre, British Petroleum, Chelsea Football Club, Duke Of Wellington's Cupola, Kings College London.

Visit our web-site for information regarding our company, our products, complete a quotation request, find further technical information etc.

Visit our web-site:

www.kingsmillearthing.co.uk

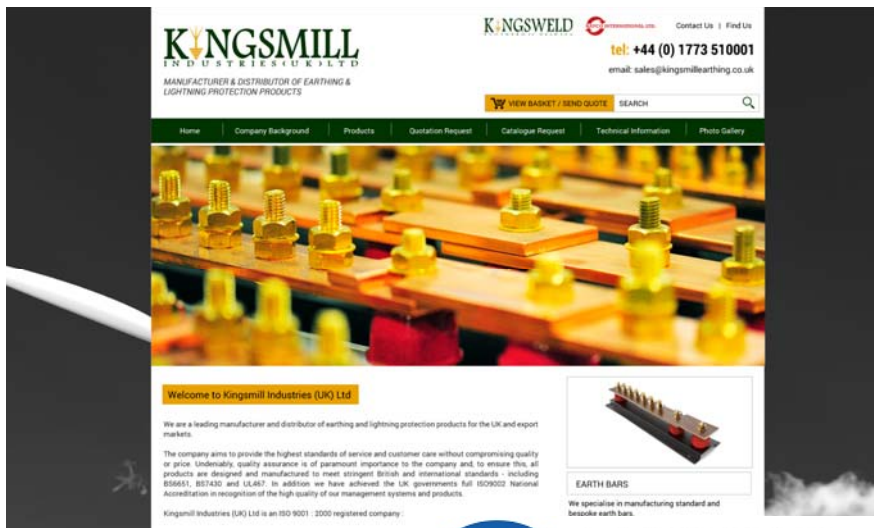

THORNE & DERRICK INTERNATIONAL

www.thorneandderrick.com

COPPERBOND EARTH ROD

NOMINAL DIAMETER (in. : mm)	LENGTH (mm)	THREAD SIZE UNC (in)	SHANK DIA. (mm)	WEIGHT (Kg)	PART No.
3/8" : 9	1200	N/A	9.50	0.62	ERCB1004
5/8" : 16	1200	5/8"	14.2	1.53	ERCB1604
5/8" : 16	1500	5/8"	14.2	1.88	ERCB1605
5/8" : 16	1800	5/8"	14.2	2.29	ERCB1606
5/8" : 16	2400	5/8"	14.2	3.00	ERCB1608
5/8" : 16	3000	5/8"	14.2	3.79	ERCB1610
3/4" : 20	1200	3/4"	17.2	2.19	ERCB2004
3/4" : 20	1500	3/4"	17.2	2.73	ERCB2005
3/4" : 20	1800	3/4"	17.2	3.27	ERCB2006
3/4" : 20	2400	3/4"	17.2	4.35	ERCB2008
3/4" : 20	3000	3/4"	17.2	5.44	ERCB2010



Copperbond earth rods, deep driven, usually provide the most cost effective earth system.

They are made from a low carbon, high tensile strength (600n/mm² minimum) steel core with a coating of molecular bonded 99.9% pure electrolytic copper.

Extendable type rods have a rolled thread (UNC2A) at each end.

Rolled threads have a higher strength than cut threads and also preserve the copper coating at the thread roots.

Copper Thickness : 250 microns : Minimum.

Material: Pure copper molecularly bonded on to a steel core.

 **BS EN 50164-2, BS 7430**

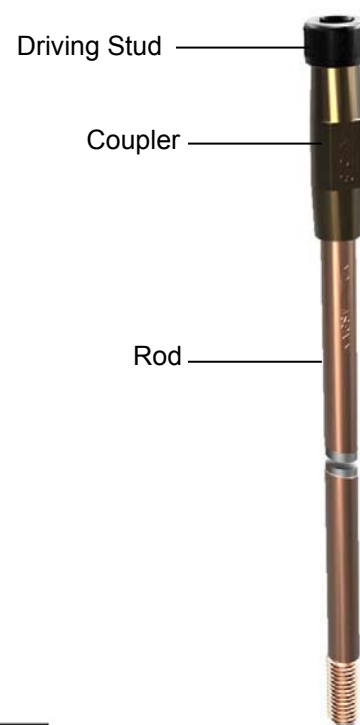

COUPLING : COPPERBOND ELECTRODE



LENGTH (mm)	BODY DIA. (mm)	DESCRIPTION	WEIGHT (Kg)	PART No.
68	22	16mm ROD COUPLING 5/8" UNC	0.08	COUP16
79	24	20mm ROD COUPLING 3/4" UNC	0.13	COUP20

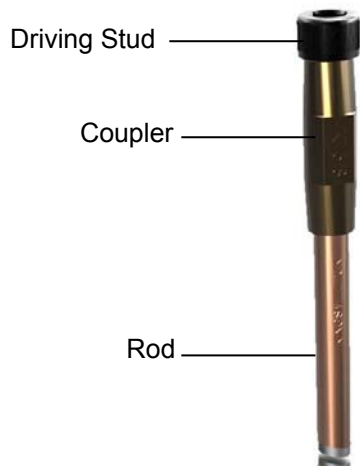

Kingsmill earth rods are manufactured from high strength, high copper content alloy to ensure adequate strength and corrosion resistance.

Kingsmill couplers are of sufficient length and are counter bored to make certain the threads of the earth rods are completely enclosed.

Material: High copper content alloy.

 **BS 7430, BS EN 50164-2 : 2008**

DRIVING STUD : COPPERBOND ELECTRODE



LENGTH (mm)	HEAD DIA. (mm)	DESCRIPTION	WEIGHT (Kg)	PART No.
54	22	16mm DRIVING STUD 5/8" UNC	0.08	DRST16
62	25	20mm DRIVING STUD 3/4" UNC	0.12	DRST20

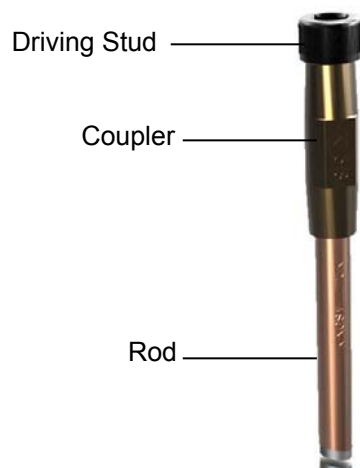

Driving studs are required to be of high strength to withstand repeated use with power hammers.

Kingsmill driving studs are made from high tensile steel with a socket-head cap screw.

Material: Steel.

BS 7430

SOLID COPPER EARTH ROD

LENGTH (mm)	INTERNAL THREAD (mm)	DIA. (mm)	WEIGHT (Kg)	PART No.
1200	M10	15	1.88	ERSC1504
1200	M10	16	2.00	ERSC1604
1500	M10	16	2.49	ERSC1605
1800	M10	16	2.99	ERSC1606
2400	M10	16	3.99	ERSC1608
3000	M10	16	4.99	ERSC1610
1200	M10	20	3.34	ERSC2004
1500	M10	20	4.18	ERSC2005
1800	M10	20	5.02	ERSC2006
2400	M10	20	6.70	ERSC2008
3000	M10	20	8.38	ERSC2010
1200	M10	25	5.18	ERSC2504
1500	M10	25	6.48	ERSC2505
1800	M10	25	7.78	ERSC2506
2400	M10	25	10.37	ERSC2508
3000	M10	25	12.97	ERSC2510



This product is used where soil conditions are more aggressive i.e. where there is high salt content.

These rods have a tapped hole at each end which allows them to be joined together by means of a coupling dowel.

Material: Copper .



BS EN 50164-2 , BS 7430.

DRIVING HEAD : SOLID COPPER EARTH ROD



LENGTH (mm)	THREAD DIA. (mm)	WEIGHT (Kg)	PART No.
40	10	0.02	DRHD16
42	10	0.05	DRHD20
45	10	0.09	DRHD25

Kingsmill driving heads are designed to protect the internal thread and top of the solid copper earth rod when being driven in to the ground.

Material: Case hardened steel.

BS 7430

COUPLING DOWEL : SOLID COPPER EARTH ROD



LENGTH (mm)	THREAD DIA. (mm)	WEIGHT (Kg)	PART No.
40	10	0.02	DWPB10

Kingsmill coupling dowels are used to join solid copper earth rods.

Material: Phosphor Bronze.

BS 7430

DRIVING SPIKE : SOLID COPPER EARTH ROD



LENGTH (mm)	THREAD DIA. (mm)	WEIGHT (Kg)	PART No.
40	10	0.02	DRSP16
55	10	0.05	DRSP20
60	10	0.10	DRSP25

Kingsmill driving spikes are designed to enable the solid copper earth rod to be driven in to the ground easily and protects the rod from being damaged.

Material: Case hardened steel.

BS 7430

STAINLESS STEEL EARTH ROD

LENGTH (mm)	INTERNAL THREAD (mm)	DIA. (mm)	WEIGHT (Kg)	PART No.
1200	M10	16	1.87	ERSS1604
1500	M10	16	2.34	ERSS1605
1800	M10	16	2.81	ERSS1606
2400	M10	16	3.75	ERSS1608
3000	M10	16	4.69	ERSS1610
1200	M10	20	2.92	ERSS2004
1500	M10	20	3.65	ERSS2005
1800	M10	20	4.38	ERSS2006
2400	M10	20	5.84	ERSS2008
3000	M10	20	7.30	ERSS2010
1200	M10	25	4.89	ERSS2504
1500	M10	25	6.12	ERSS2505
1800	M10	25	7.34	ERSS2506
2400	M10	25	9.79	ERSS2508
3000	M10	25	12.24	ERSS2510



Made from austenitic steel to British standards.

The stainless steel rod is similar to copper rods but are more anodic than copper and are useful where galvanic corrosion is possible.

The current carrying capacity of the stainless steel rod in relation to copper is poor.

These rods have a tapped hole at each end which allows them to be joined together by means of a coupling dowel.

Can be supplied in different grades if required.

Material: Stainless Steel.



BS EN 50164-2 , BS 7430.



DRIVING HEAD : STAINLESS STEEL EARTH ROD



LENGTH (mm)	THREAD DIA. (mm)	WEIGHT (Kg)	PART No.
40	10	0.02	DRHD16
42	10	0.05	DRHD20
45	10	0.09	DRHD25

Kingsmill driving heads are designed to protect the internal thread and top of the stainless steel earth rod when being driven in to the ground.

Material: Case hardened steel.

BS 7430

COUPLING DOWEL : STAINLESS STEEL EARTH ROD



LENGTH (mm)	THREAD DIA. (mm)	WEIGHT (Kg)	PART No.
40	10	0.02	DWSS10

Kingsmill coupling dowels are used to join stainless steel earth rod.

Material: Stainless Steel.

BS 7430

DRIVING SPIKE : STAINLESS STEEL EARTH ROD



LENGTH (mm)	THREAD DIA. (mm)	WEIGHT (Kg)	PART No.
40	10	0.02	DRSP16
55	10	0.05	DRSP20
60	10	0.10	DRSP25

Kingsmill driving spikes are designed to enable the solid copper earth rod to be driven in to the ground easily and protects the rod from being damaged.

Material: Case hardened steel.

BS 7430

BENTONITE : MOISTURE RETAINING CLAY

MATERIAL	WEIGHT (Kg)	PART No.
GRANULATED MOISTURE RETAINING CLAY	25	BENT01
POWDER MOISTURE RETAINING CLAY	25	BENT02



Bentonite is used as a backfill to reduce soil resistivity. When mixed with water, it swells to several times its dry volume. The moisture content can be retained for a considerable time. Further moisture can be absorbed during rainfall etc. It can be supplied in either powder or granular form.

Dependent on soil conditions, 18 No. 25Kg bags creates a volume of 1m³.

Earthing Compound:

Granular: Granular is the preferred option for filling trenches where the conductor is covered with Bentonite and then water poured over and mixed in the trench.

Powder: Powder is the preferred method for pouring into bore holes to ensure the mixture is of a thin enough consistency to reach the bottom of the bore hole. If diamond drilling is required for deep holes, possible 40m depths and deeper and the Bentonite is to be pumped through the core in to the hole, then powder would be the preferred option.

Material: Sodium carbonate activated calcium Montmorillonite clay. The product is a naturally occurring substance with no known ecological hazards and can be disposed of as non hazardous waste.

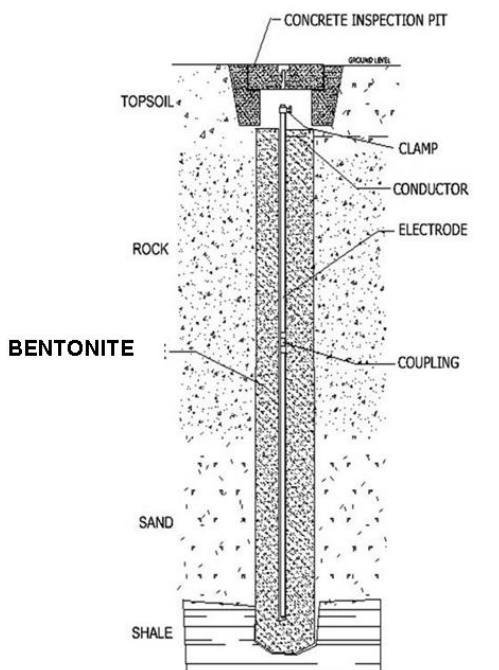

TYPICAL ELECTRODE INSTALLATION

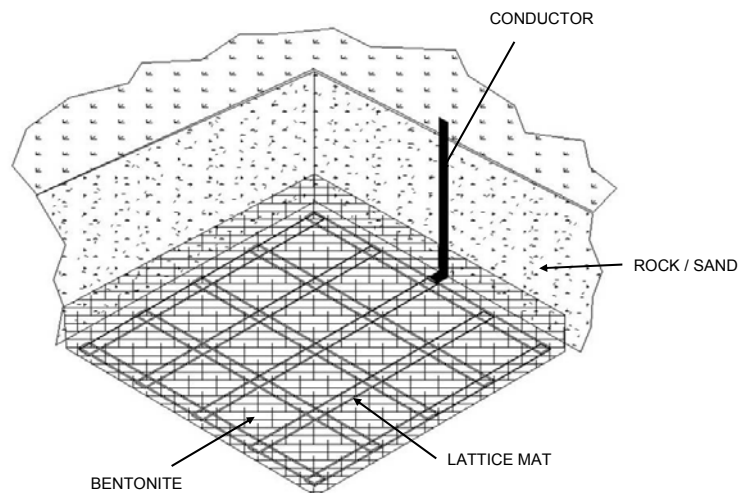

TYPICAL LATTICE MAT INSTALLATION



THORNE & DERRICK INTERNATIONAL

MARCONITE : GRANULATED CONDUCTIVE MEDIUM



Introduction:

Marconite® is the world's premium electrically conductive aggregate material. Used as a back-fill to enhance the effects of earth electrodes, Marconite® enables electrical engineers to achieve permanent, stable and low resistance earthing solutions, even in difficult ground conditions.

Specifically developed and manufactured for the needs of the earthing industry, for over 40 years Marconite® has allowed electrical engineers to tackle the toughest conditions and achieve the satisfactory earthing of installations throughout the world.

About:

Marconite® conducts electricity much in the same way as metals, through the movement of electrons.

Traditional earthing materials such as Bentonite conduct electricity through the movement of charged ions. These ions require the presence of an effective electrolyte, such as water and the presence of salts. Unlike **Marconite®**, ionic based systems are subject to drying out and without water they do not conduct electricity. **Marconite®** does not need water to conduct electricity and so does not suffer any effects from drying out.

Applications:

Marconite® has a long and proven track record and has been used within critical earthing solutions to a variety of industries, including:

- ◆ Lightning conductor earthing.
- ◆ Power generation and distribution.
- ◆ Oil and gas production and distribution facilities.
- ◆ Rail, underground and transport networks.
- ◆ Telecommunications, High Speed Broadband and Media.
- ◆ Utilities and Water treatment.
- ◆ Defence facilities and equipment.
- ◆ Anti-static environments.



Benefits:

Low resistivity: 0.001 ohm.m is extremely low when compared to Bentonite's 3 ohm.m.

Versatile: suitable for most ground conditions and becomes a permanent, solid structure that it is not prone to shrinking, drying out or being washed away.

Cost effective: it is a permanent solution; there is no need to remove and replace or 'maintain' it with additional water / salts every few years in order to achieve the desired earth values.

Chemically inert: is non-corrosive to steel or copper, does not attack cement structures and has a pH within the neutral range.

High strength: can be used as part of the building structure itself and can achieve strengths higher than Grade 25 concrete.

Easy to use: forms a concrete like material that from first pour, achieves a low resistance earth, no need to wait or return to test.

Marconite® is a synthetic material manufactured specifically for use in earthing applications and, unlike Bentonite, it is not a naturally occurring mineral or ore.

Its distinctive properties result from a unique manufacturing process, utilising specific raw material feedstock's, carefully selected and mixed in tightly controlled ratio's before undergoing a range manufacturing process and thermal treatments.

The resulting product is a precisely measured, granular material, dark grey in colour, that is virtually dust free and with exceptional electrical properties. This is then packaged in high strength, UV resistant valve topped sacks and palletised.

Marconite® is the best at what it does because it is manufactured to be that way.



www.thorneandderrick.com

MARCONITE : GRANULATED CONDUCTIVE MEDIUM



MATERIAL	WEIGHT (Kg)	PART No.
MARCONITE CONCRETE (PRE-MIXED)	25	MARC01
MARCONITE CONCRETE	25	MARC02

Marconite is a granulated conductive medium designed to replace the conventional aggregate in concrete and thereby provide a medium with good electrical conductivity and high strength.

It can provide a permanent solution to problems in electrical / constructual situations.

Marconite® is a dark grey, granular material that replaces traditional sand and aggregate materials used within concretes mixes. It should be mixed in the ratio of 3 parts of **Marconite®** to 1 part cement by weight with the addition of 1 litre of water per 5 Kg of total mix, i.e.

3 x 25 Kg bags of Marconite.

1 x 25 Kg bag of Cement.

20 litres (25 Kg) of water.

When mixed as described above, it forms a relatively dry material with an 'as poured' density of around 1300 Kg / m³. The water content may be adjusted as the application requires, but this will affect the concretes final compressive strength and the drying times accordingly. Typically **Marconite®** concretes are touch dry within hours but can be several days before being fully cured.

Marconite® is chemically inert with very low soluble sulphate content. It can be used with all conventional types of cement, as well as most proprietary resin-based cements, adhesives and gypsum plasters.

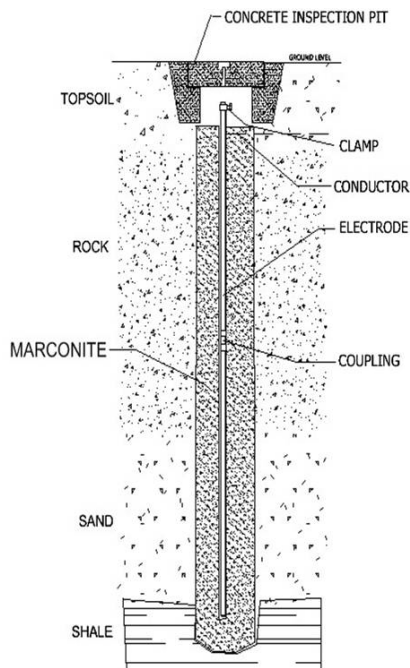

TYPICAL ELECTRODE INSTALLATION

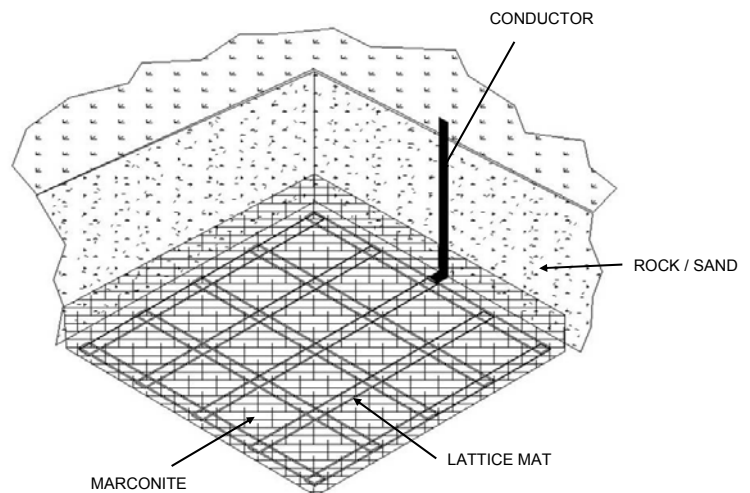

TYPICAL LATTICE MAT INSTALLATION



THORNE & DERRICK INTERNATIONAL

CONCRETE INSPECTION PIT



DESCRIPTION	WEIGHT (Kg)	PART No.
CONCRETE INSPECTION PIT	25	CPIT

Kingsmill Concrete Pits are suitable for load rating to 4,500Kg and is suitable for most types of Earthing and lightning protection installations.

The inspection pit protects the earth rod connection and makes it available for inspection. The pit can have an earth bar fitted diagonally in slots provided for multiple connections.

Pit dimensions: (mm) 315 x 315 x 165 (W x D x H)

Material: Concrete.

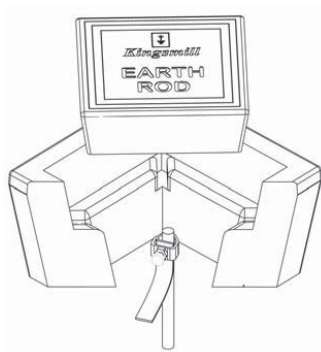

EARTH BAR : CONCRETE INSPECTION PIT

DESCRIPTION	OVERALL SIZE (mm) L x W x T	HOLE SIZE (mm)	WEIGHT (Kg)	PART No.
5 HOLE PIT BAR	300 x 25 x 6	11	0.49	PBAR5
7 HOLE PIT BAR	300 x 25 x 6	11	0.47	PBAR7



PBAR5



PBAR7

Kingsmill inspection pit earth bars are used to facilitate testing of the earth electrode or earthing system.

The earth bar can be fitted diagonally in slots provided for multiple connections.

Material: Copper to BS EN 13601.

CONCRETE INSPECTION PIT : LIGHTWEIGHT

DESCRIPTION	WEIGHT (Kg)	PART No.
LIGHTWEIGHT CONCRETE INSPECTION PIT	16	CPIT/LW



Kingsmill Concrete Pits are suitable for load rating to 4,500Kg and is suitable for most types of Earthing and lightning protection installations.

The inspection pit protects the earth rod connection and makes it available for inspection. The pit can have an earth bar fitted diagonally in slots provided for multiple connections.

Pit dimensions: (mm) 275 x 275 x 130 (W x D x H)

Material: Concrete.

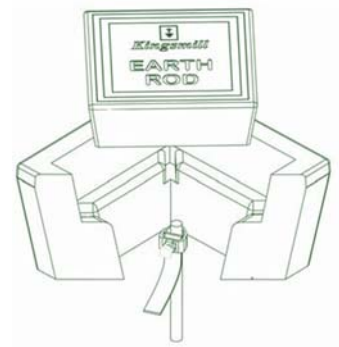

EARTH BAR : CONCRETE INSPECTION PIT LIGHTWEIGHT

DESCRIPTION	OVERALL SIZE (mm) L x W x T	HOLE SIZE (mm)	WEIGHT (Kg)	PART No.
5 HOLE PIT BAR	230 x 25 x 6	11	0.34	PBAR5/LW
7 HOLE PIT BAR	230 x 25 x 6	11	0.33	PBAR7/LW



PBAR5/LW



PBAR7/LW

Kingsmill inspection pit earth bars are used to facilitate testing of the earth electrode or earthing system.

The earth bar can be fitted diagonally in slots provided for multiple connections.

Material: Copper to BS EN 13601.

PLASTIC INSPECTION PIT



DESCRIPTION	WEIGHT (Kg)	PART No.
PLASTIC INSPECTION PIT	1.28	PPIT-G

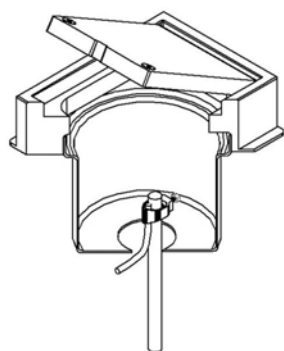

Kingsmill Plastic Pits are suitable for load rating to 5,000Kg and is suitable for most types of Earthing and lightning protection installations.

The inspection pit protects the earth rod connection and makes it available for inspection. The pit can have an earth bar fitted diagonally in slots provided for multiple connections.

Pit dimensions: (mm) 220 x 250 x 220 (W x D x H)

Material: Polypropylene.



EARTH BAR : PLASTIC INSPECTION PIT



PBAR5/PP



PBAR7/PP

DESCRIPTION	OVERALL SIZE (mm) L x W x T	HOLE SIZE (mm)	WEIGHT (Kg)	PART No.
5 HOLE PIT BAR	200 x 25 x 6	11	0.31	PBAR5/PP
7 HOLE PIT BAR	200 x 25 x 6	11	0.30	PBAR7/PP

Kingsmill inspection pit earth bars are used to facilitate testing of the earth electrode or earthing system.

The earth bar can be fitted diagonally in slots provided for multiple connections.

Material: Copper to BS EN 13601.

SINGLE FLANGE EARTH ROD SEAL

ROD DIA. (in : mm)	ROD TYPE	LENGTH (mm)	PART No.
5/8" UNC	COPPERBOND	300	KES-58
3/4" UNC	COPPERBOND	300	KES-34
15mm	SOLID COPPER OR STAINLESS STEEL	300	KES-15
16mm	SOLID COPPER OR STAINLESS STEEL	300	KES-16
20mm	SOLID COPPER OR STAINLESS STEEL	300	KES-20



A waterproof earth electrode single flange seal for use in constructions where internal earths are specified.

The unique design allows the seals to be used in conjunction with a broad range of rod diameters including 5/8" and 3/4" UNC.

For use with the PPIT-G - Plastic Inspection Pit.

Installation Instructions are available upon request.

Material: High density plastic.



DOUBLE FLANGE EARTH ROD SEAL

ROD DIA. (in : mm)	ROD TYPE	LENGTH (mm)	PART No.
5/8" UNC	COPPERBOND	1200	KES-58-DBL
3/4" UNC	COPPERBOND	1200	KES-34-DBL
15mm	SOLID COPPER OR STAINLESS STEEL	1200	KES-15-DBL
16mm	SOLID COPPER OR STAINLESS STEEL	1200	KES-16-DBL
20mm	SOLID COPPER OR STAINLESS STEEL	1200	KES-20-DBL

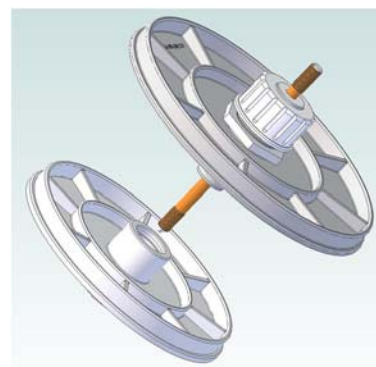

A waterproof earth electrode double flange seal for use in constructions where internal earths are specified.

The unique design allows the seals to be used in conjunction with a broad range of rod diameters including 5/8" and 3/4" UNC.

For use with the PPIT-G - Plastic Inspection Pit.

Installation Instructions are available upon request.

Material: High density plastic.



THORNE &
DERRICK
INTERNATIONAL

SOLID COPPER PLATES

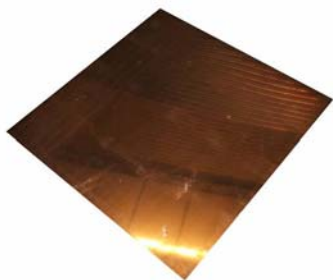

LENGTH x WIDTH (mm)	THICKNESS (mm)	SURFACE AREA (m ²)	WEIGHT (Kg)	PART No.
600 x 600	1.5	0.73	5.00	SCEP615
600 x 600	3.0	0.73	11.20	SCEP630
900 x 900	1.5	1.63	9.74	SCEP915
900 x 900	3.0	1.63	21.75	SCEP930

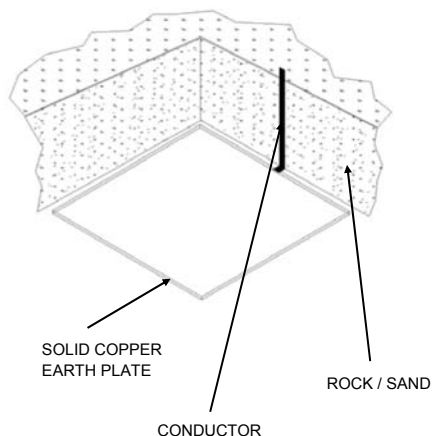

Kingsmill solid copper earth plates are used as part of an earthing network.

They provide a long lasting solution where earth rods are unsuitable.

Generally used as an electrode where significant amounts of fault current can be encountered.

OTHER SIZES AVAILABLE UPON REQUEST.

Material: Copper to BS EN 12163 (formerly BS 2874).

LATTICE COPPER EARTH MATS



LENGTH x WIDTH (mm)	THICKNESS (mm)	GRID	SURFACE AREA (m ²)	WEIGHT (Kg)	PART No.
600 x 600	3.0	5 BAR	0.31	4.02	LCEM630
900 x 900	3.0	5 BAR	0.65	6.03	LCEM930

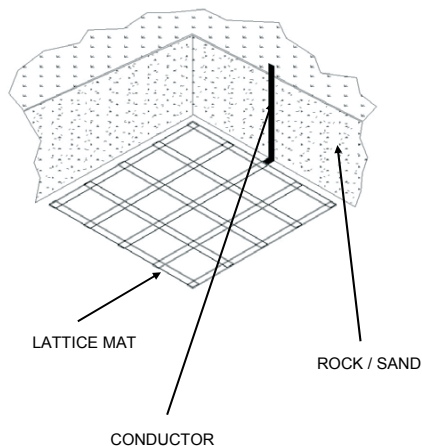

Kingsmill lattice copper earth mats are used where step potential could cause problems.

They are a lower cost option to the solid plates and when used with Bentonite, they provide a long lasting earth solution.

Generally used as an electrode where significant amounts of fault current can be encountered.

OTHER SIZES AVAILABLE UPON REQUEST.

Material: Copper to BS EN 13601 (formerly BS 1432).

ROD TO TAPE CLAMP : A TYPE

ROD DIA. (in : mm)	MAX CONDUCTOR SIZE (mm)	WEIGHT (Kg)	PART No.
5/8 : 16 3/4 : 20	29 x 16 29 x 13	0.15	CLA2530
5/8 : 16 3/4 : 20	28 x 22 28 x 20	0.23	CLA2510
5/8 : 16 3/4 : 20	47 x 18 47 x 14	0.24	CLA4012
5/8 : 16 3/4 : 20	54 x 16 54 x 13	0.30	CLA5060

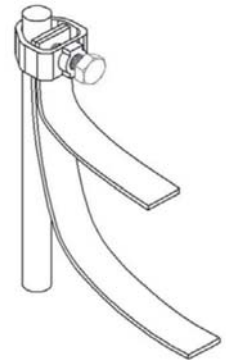
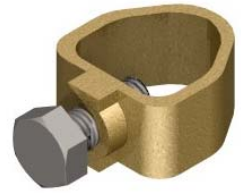

Kingsmill rod to tape type 'A' clamps are designed to join various sizes of conductor tape to the earth electrode.

The clamps have a high resistance to corrosion and are mechanically strong to ensure a lasting connection.

Material: High strength copper alloy.

Tightening Torque: 15Nm.

 **BS EN 50164-1 Class H, BS 7430**

ROD TO TAPE CLAMP : U BOLT SINGLE PLATE TYPE

ROD DIA. (in : mm)	HOLE CENTRES (mm)	WEIGHT (Kg)	PART No.
5/8 : 16	37	0.20	CLUB16
3/4 : 20	37	0.21	CLUB20
1 : 25	37	0.22	CLUB25
1 1/4 : 30	43	0.23	CLUB30
2 : 50	64	0.42	CLUB50

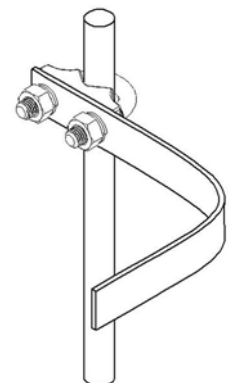

Kingsmill rod to tape type 'U' Bolt single plate clamps are designed to join various sizes of conductor tape to the earth electrode.

The clamps have a high resistance to corrosion and are mechanically strong to ensure a lasting connection.

Material: Body - High strength copper alloy.

'U' bolt material - Copper.

Tightening Torque: 12Nm.

 **BS EN 50164-1 Class H, BS 7430**

ROD TO TAPE CLAMP : U BOLT DOUBLE PLATE TYPE



ROD DIA. (in : mm)	TAPE WIDTH (mm)	WEIGHT (Kg)	PART No.
5/8 : 16	25	0.30	CLUB16-2
3/4 : 20	25	0.34	CLUB20-2
1 : 25	25	0.38	CLUB25-2

Kingsmill rod to tape type 'U' Bolt double plate clamps are designed to join 25 x 3 conductor tape to the earth electrode / rebar, without the need to drill the tape.

The clamps have a high resistance to corrosion and are mechanically strong to ensure a lasting connection.

Material: Body - High strength copper alloy.

'U' bolt material - Copper.

Tightening Torque: 12Nm.

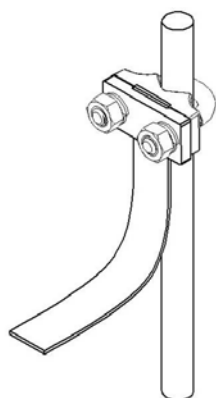

ROD TO CABLE CLAMP : JAB TYPE



ROD DIA. (in : mm)	MAX CONDUCTOR SIZE (mm ²)	WEIGHT (Kg)	PART No.
5/8 : 16 3/4 : 20	6 - 70	0.05	CLJA16
5/8 : 16 3/4 : 20	6 - 95	0.06	CLJA20

Kingsmill rod to cable type JAB clamps are designed to join various sizes of cable to the earth electrode.

The clamps have a high resistance to corrosion and are mechanically strong to ensure a lasting connection.

Material: High strength copper alloy.

Tightening Torque: 12Nm.

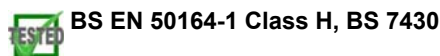
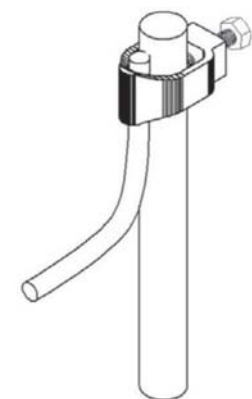

ROD TO CABLE CLAMP : GUV TYPE

ROD DIA. (in : mm)	CONDUCTOR RANGE (mm ²)	WEIGHT (Kg)	PART No.
5/8 : 16 3/4 : 20	16 - 70	0.38	CGUV16
5/8 : 16 3/4 : 20	70 - 185	0.38	CGUV70
5/8 : 16 3/4 : 20	150 - 300	0.62	CGUV150

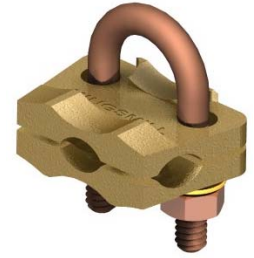

Kingsmill GUV type clamps are designed to join various sizes of cable to earth electrodes / rebar's etc.

The clamps have a high resistance to corrosion and are mechanically strong to ensure a lasting connection.

Material: Body - High strength copper alloy.
'U' bolt material - Copper.

Tightening Torque: 12Nm

 **BS EN 50164-1, Class H**

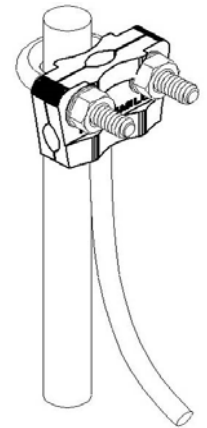

ROD TO CABLE CLAMP : KEYHOLE TYPE

ROD DIA. (in / mm)	ROD TYPE	BOLT SIZE	WEIGHT (Kg)	PART No.
9.5mm	COPPERBOND	M08	0.08	CLUG10
5/8" UNC	COPPERBOND	M10	0.20	CLUG16
15mm	SOLID COPPER	M10	0.20	CLUG15S
3/4" UNC	COPPERBOND	M10	0.35	CLUG20
20mm	SOLID COPPER	M10	0.35	CLUG20S



Kingsmill rod to cable lug type clamps are designed to join various sizes of compression lugs to the earth electrode.

The clamps have a high resistance to corrosion and are mechanically strong to ensure a lasting connection.

Material: High strength copper alloy.

Tightening Torque: 12Nm.

 **BS EN 50164-1 Class H, BS 7430**

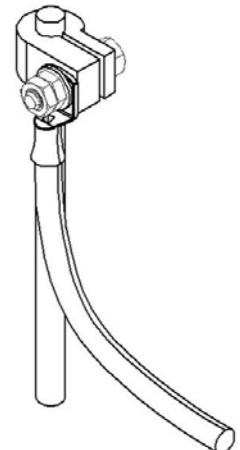

B BOND : FLAT SURFACES



CONDUCTOR SIZE (mm)	CONDUCTOR MATERIAL	BOLT SIZE	WEIGHT (Kg)	PART No.
25 x 3	COPPER	M10	0.10	BBCB
25 x 3	ALUMINIUM	M10	0.06	BBAB

Kingsmill 'B' type bond connections are designed to bond either copper or Aluminium conductor to flat metal surfaces.

Material: BBCB - Gunmetal.

BBAB - Aluminium.

Tightening Torque: 17Nm.

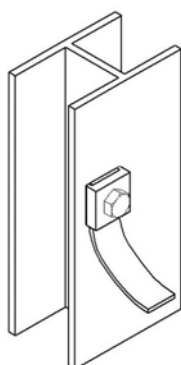

 **BS EN 50164-1 Class H, BS 7430**

RWP BOND : PIPE WORK

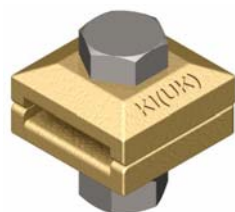

CONDUCTOR SIZE (mm)	CONDUCTOR MATERIAL	BOLT SIZE	WEIGHT (Kg)	PART No.
25 x 3	COPPER	M10	0.18	CRWB
25 x 3	ALUMINIUM	M10	1.08	ARWB

Kingsmill RWP type bond connections are designed to connect flat conductor to circular objects i.e. pipework and hand rails etc.

RWP bonds are available in either Gunmetal or Aluminium to suit your application.

Material: CRWB - Gunmetal.

ARWB - Aluminium.

Tightening Torque: 12Nm.

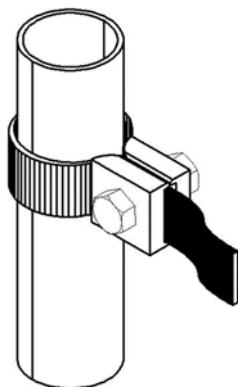

 **BS EN 50164-1 Class H, BS 7430**

TOWER EARTH CLAMP

CONDUCTOR SIZE RANGE (mm ²)	DESCRIPTION	CONDUCTOR MATERIAL	WEIGHT (Kg)	PART No.
25 - 50	SINGLE PLATE TOWER EARTH CLAMP	COPPER	0.09	TEC2550
25 - 50	SINGLE PLATE TOWER EARTH CLAMP ALU	ALUMINIUM	0.06	TEA2550
16 - 70	DOUBLE PLATE TOWER EARTH CLAMP	COPPER	0.13	TEC1670
70 - 120	DOUBLE PLATE TOWER EARTH CLAMP	COPPER	0.22	TEC70120

Kingsmill tower earth clamps are designed to bond either copper or aluminium conductor to flat metal surfaces.

Material: Gunmetal / Aluminium.

Tightening Torque: 12Nm.

 **BS EN 50164-1 Class H, BS 7430**

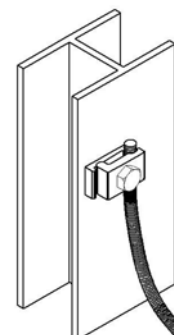
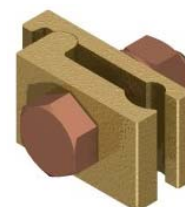

EARTH POINTS : SINGLE HOLE & TWO HOLE

COVER PLATE	TAIL	COVER PLATE CONDUCTOR RANGE (mm)	WEIGHT (Kg)	PART No.
NO	NO	N/A	0.17	EBP1
NO	NO	N/A	0.30	EBP2
YES	NO	25 x 3 TAPE, 70mm ² CABLE	0.42	EBP2P
YES	NO	25 x 3 TAPE, 50mm ² CABLE (8mm DIA.)	0.42	EBP2P-08

Kingsmill earth points are installed to provide continuity and they also offer multiple bonding points.

Material: Gunmetal.

Tightening Torque: 8Nm.

 **BS EN 50164-1 Class H, BS 7430**



EARTH POINTS : FOUR HOLE

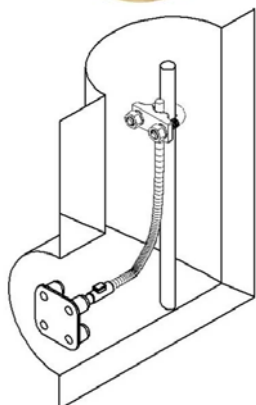

COVER PLATE	TAIL	COVER PLATE CONDUCTOR RANGE	WEIGHT (Kg)	PART No.
NO	NO	N/A	0.42	EBP4

Kingsmill earth points are installed to provide continuity and they also offer multiple bonding points.

Material: Gunmetal.

Tightening Torque: 8Nm.

 **BS EN 50164-1 Class H, BS 7430**

EARTH POINTS : COMPLETE WITH TAIL



COVER PLATE	TAIL LENGTH (mm)	COVER PLATE CONDUCTOR RANGE	WEIGHT (Kg)	PART No.
NO	500	N/A	0.46	EBP1-T
NO	500	N/A	0.62	EBP2-T
NO	500	N/A	0.75	EBP4-T
YES	500	25 x 3 TAPE, 70mm ² CABLE	0.75	EBP2P-T
YES	500	25 x 3 TAPE, 50mm ² CABLE (8mm DIA.)	0.75	EBP2P-08-T

Material: Body: Gunmetal.

Tail: 6491X Green/Yellow copper cable.

Tightening Torque: 8Nm.

 **BS EN 50164-1 Class H, BS 7430**

Different length tails can be provided upon request.

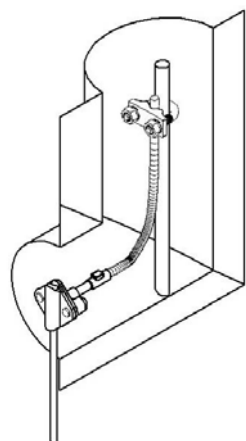

TYPICAL EBP2P-08-T

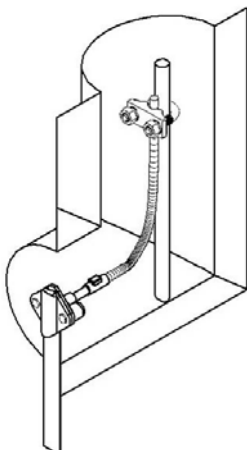

TYPICAL EBP2P-T

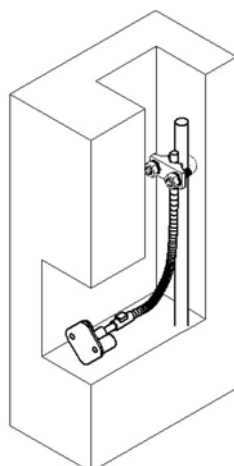

TYPICAL EBP2-T

EARTH BOSS

LENGTH (mm)	DIAMETER (mm)	THREAD SIZE	WEIGHT (Kg)	PART No.
25	25	M08	0.09	EBOSS2525M08
30	30	M08	0.16	EBOSS3030M08
30	30	M10	0.18	EBOSS3030M10
30	40	M08	0.22	EBOSS3040M08
30	40	M10	0.24	EBOSS3040M10
30	50	M08	0.27	EBOSS3050M08
30	50	M10	0.29	EBOSS3050M10
40	30	M10	0.31	EBOSS4030M10
40	30	M12	0.34	EBOSS4030M12
40	40	M10	0.41	EBOSS4040M10
40	40	M12	0.43	EBOSS4040M12
40	50	M10	0.51	EBOSS4050M10
40	50	M12	0.53	EBOSS4050M12
50	30	M10	0.48	EBOSS5030M10
50	30	M12	0.50	EBOSS5030M12
50	40	M10	0.63	EBOSS5040M10
50	40	M12	0.65	EBOSS5040M12
50	50	M10	0.78	EBOSS5050M10
50	50	M12	0.78	EBOSS5050M12

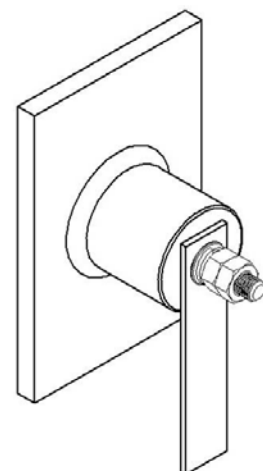

Earth Boss for welding to steel vessel, tanks and structures etc.

Connections to be wrapped with Denso Tape to stop the ingress of moisture.

Comes complete with A2 Stainless Steel dowel, flat washer, spring washer & two nuts.

Phosphor Bronze fixing assembly is available upon request. Add "/PB" to the end of the Part Number to specify Phosphor Bronze Assembly.

Other sizes / configurations available upon request.

Material: Mild steel - BS 970 230M07.

FLEXIBLE FLAT COPPER BRAID BOND

COPPER BRAID

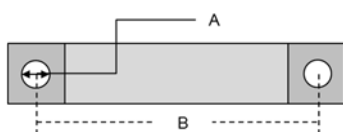

OVERALL DIMENSIONS (mm)	LENGTH (B) (mm)	HOLE DIA. (A) (mm)	CROSS-SEC AREA (mm ²)	WEIGHT (Kg)	PART No.
12 x 1	200	7.0	6.0	0.01	FB200/6/7
12 x 1	400	7.0	6.0	0.02	FB400/6/7
15 x 1.5	200	7.0	10	0.02	FB200/10/7
15 x 1.5	400	7.0	10	0.04	FB400/10/7
19 x 2.5	200	9.0	16	0.03	FB200/16/9
19 x 2.5	400	9.0	16	0.06	FB400/16/9
25 x 3	200	11	25	0.05	FB200/25/11
25 x 3	400	11	25	0.10	FB400/25/11
25 x 3.5	200	11	35	0.09	FB200/35/11
25 x 3.5	400	11	35	0.15	FB400/35/11
30 x 5	200	11	50	0.10	FB200/50/11
30 x 5	400	11	50	0.20	FB400/50/11
32 x 6	200	13	70	0.13	FB200/70/13
32 x 6	400	13	70	0.25	FB400/70/13
37 x 6	200	13	95	0.19	FB200/95/13
37 x 6	400	13	95	0.37	FB400/95/13
45 x 6	200	17	120	0.23	FB200/120/17
45 x 6	400	17	120	0.46	FB400/120/17
50 x 8	200	17	150	0.30	FB200/150/17
50 x 8	400	17	150	0.60	FB400/150/17

Flexible copper or flexible tinned copper braid terminated with pressed ferrule connector at each end, suitable for bonding gates, doors, fences etc.

Other sizes, materials, hole sizes etc. available upon request.

Material: Copper / tinned copper.

BS EN 13602



Special Braids available upon request.

TINNED COPPER BRAID

OVERALL DIMENSIONS (mm)	LENGTH (B) (mm)	HOLE DIA.(A) (mm)	CROSS-SEC AREA (mm ²)	WEIGHT (Kg)	PART No.
12 x 1	200	7.0	6.0	0.01	FBT200/6/7
12 x 1	400	7.0	6.0	0.02	FBT400/6/7
15 x 1.5	200	7.0	10	0.02	FBT200/10/7
15 x 1.5	400	7.0	10	0.04	FBT400/10/7
19 x 2.5	200	9.0	16	0.03	FBT200/16/9
19 x 2.5	400	9.0	16	0.06	FBT400/16/9
25 x 3	200	11	25	0.05	FBT200/25/11
25 x 3	400	11	25	0.10	FBT400/25/11
25 x 3.5	200	11	35	0.09	FBT200/35/11
25 x 3.5	400	11	35	0.15	FBT400/35/11
30 x 5	200	11	50	0.10	FBT200/50/11
30 x 5	400	11	50	0.20	FBT400/50/11
32 x 6	200	13	70	0.13	FBT200/70/13
32 x 6	400	13	70	0.25	FBT400/70/13
37 x 6	200	13	95	0.19	FBT200/95/13
37 x 6	400	13	95	0.37	FBT400/95/13
45 x 6	200	17	120	0.23	FBT200/120/17
45 x 6	400	17	120	0.46	FBT400/120/17
50 x 8	200	17	150	0.30	FBT200/150/17
50 x 8	400	17	150	0.60	FBT400/150/17

FLEXIBLE CIRCULAR COPPER BRAID BOND

COPPER BRAID

OVERALL BRAID DIAMETER (mm)	LENGTH (B) (mm)	HOLE DIA. (A) (mm)	CROSS-SEC AREA (mm ²)	WEIGHT (Kg)	PART No.
4.2	200	7.0	6.0	0.01	CB200/6/7
4.2	400	7.0	6.0	0.02	CB400/6/7
5.4	200	7.0	10	0.02	CB200/10/7
5.4	400	7.0	10	0.04	CB400/10/7
7.0	200	9.0	16	0.03	CB200/16/9
7.0	400	9.0	16	0.06	CB400/16/9
8.5	200	11	25	0.05	CB200/25/11
8.5	400	11	25	0.10	CB400/25/11
11.5	200	11	50	0.10	CB200/50/11
11.5	400	11	50	0.20	CB400/50/11
14.5	200	13	70	0.13	CB200/70/13
14.5	400	13	70	0.25	CB400/70/13
16.0	200	13	95	0.19	CB200/95/13
16.0	400	13	95	0.37	CB400/95/13

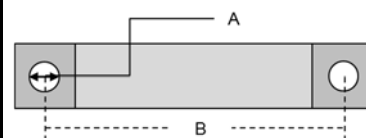

TINNED COPPER BRAID

OVERALL DIAMETER (mm)	LENGTH (B) (mm)	HOLE DIA. (A) (mm)	CROSS-SEC AREA (mm ²)	WEIGHT (Kg)	PART No.
4.2	200	7.0	6.0	0.01	CBT200/6/7
4.2	400	7.0	6.0	0.02	CBT400/6/7
5.4	200	7.0	10	0.02	CBT200/10/7
5.4	400	7.0	10	0.04	CBT400/10/7
7.0	200	9.0	16	0.03	CBT200/16/9
7.0	400	9.0	16	0.06	CBT400/16/9
8.5	200	11	25	0.05	CBT200/25/11
8.5	400	11	25	0.10	CBT400/25/11
11.5	200	11	50	0.10	CBT200/50/11
11.5	400	11	50	0.20	CBT400/50/11
14.5	200	13	70	0.13	CBT200/70/13
14.5	400	13	70	0.25	CBT400/70/13
16.0	200	13	95	0.19	CBT200/95/13
16.0	400	13	95	0.37	CBT400/95/13



Flexible copper or flexible tinned copper braid terminated with pressed ferrule connectors at each end, suitable for bonding gates, doors, fences etc.

Other sizes, materials, hole sizes etc. available upon request.

Material: Copper / tinned copper.



Special Braids available upon request.



MANUFACTURING PROCESSES

All our earth bars are manufactured in our dedicated UK factory from raw stock and go through a series of manufacturing processes by our skilled staff, thereby enabling us to manufacture and assemble any earth bar with consistent quality control.

We use quality raw stock materials to British Standards and as with all our products, the earth bars are manufactured and packaged to an exceptional standard.

Q. - Why choose a Kingsmill earth bar?

A. - The Bases are Powder Coated to reduce the risk of corrosion.

A. - Pre-drilled fixing holes for ease of installation. (These can be threaded if required).

A. - We use the highest quality raw materials.

A. - We offer an extensive range.

A. - Where you can't find your requirement, we can manufacture to your exact specification.

A. - The manufacturing process ensures you receive a quality product consistently.

A. - The manufacturing process allows us to manufacture the earth bars efficiently without compromising quality.

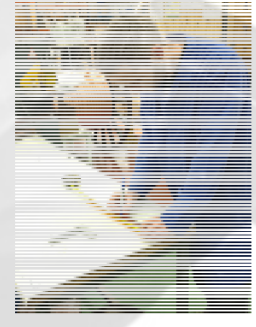
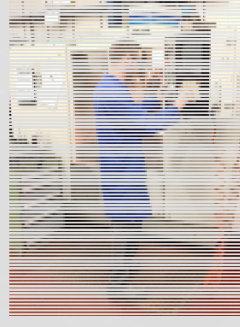
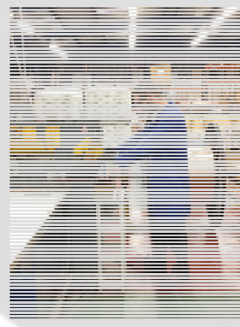
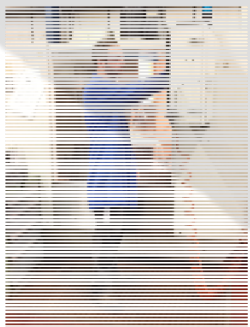
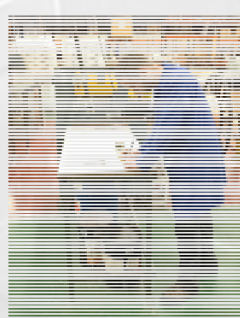
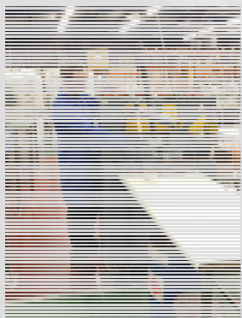

MATERIAL SPECIFICATION

ITEM No.	DESCRIPTION	MATERIAL	WEIGHT (Kg)
1	M10 x 25mm HEX SET	BRASS	0.03
2	M10 FULL NUT	BRASS	0.01
3	M10 FLAT WASHER	BRASS	0.002
4	M10 x 40mm ALL THREAD	BRASS	0.02
5	M10 FULL NUT	BRASS	0.01
6	M10 FLAT WASHER	BRASS	0.002
7	50 x 6mm COPPER BAR	HDHC COPPER	2.67/m
8	M10 x 35 INSULATOR	REINFORCED POLYESTER C/W BRASS INSERTS	0.08
9	M10 SPRING WASHER	BZP MILD STEEL	0.002
10	M10 x 12mm HEX SET	BZP MILD STEEL	0.002
11	100 (W) x 15mm (H) BASE	POWDER COATED STEEL	1.00/m

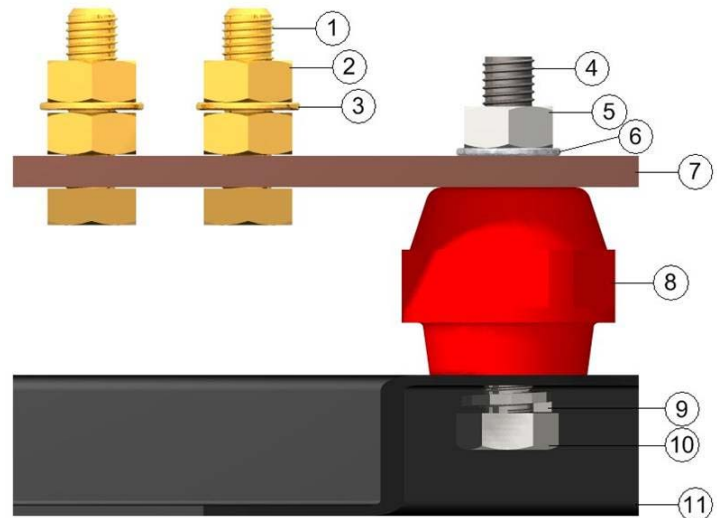

DISCONNECTING LINK

DESCRIPTION	DIMENSIONS (mm) L x W x H	PART No.
DISCONNECTING LINK	125 x 100 x 90	ELINK

The disconnecting link is mainly used to offer a temporary break in the connection to earth allowing the testing of an earth rod whilst disconnecting from the lightning protection system.

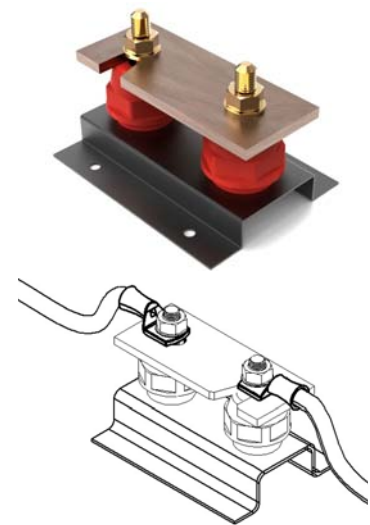

DISCONNECTING LINK : TINNED

DESCRIPTION	DIMENSIONS (mm) L x W x H	PART No.
DISCONNECTING LINK TINNED	125 x 100 x 90	ELINK/T

The tinned disconnecting link is mainly used to offer a temporary break in the connection to earth allowing the testing of an earth rod whilst disconnecting from the lightning protection system.



STANDARD



DESCRIPTION	DIMENSIONS (mm)	
	L x W x H	
6 WAY EARTH BAR	300 x 100 x 90	EBAR6
8 WAY EARTH BAR	450 x 100 x 90	EBAR8
10 WAY EARTH BAR	450 x 100 x 90	EBAR10
12 WAY EARTH BAR	520 x 100 x 90	EBAR12
14 WAY EARTH BAR	650 x 100 x 90	EBAR14
16 WAY EARTH BAR	650 x 100 x 90	EBAR16
18 WAY EARTH BAR	800 x 100 x 90	EBAR18
20 WAY EARTH BAR	800 x 100 x 90	EBAR20
22 WAY EARTH BAR	900 x 100 x 90	EBAR22
24 WAY EARTH BAR	1050 x 100 x 90	EBAR24
26 WAY EARTH BAR	1050 x 100 x 90	EBAR26
28 WAY EARTH BAR	1250 x 100 x 90	EBAR28
30 WAY EARTH BAR	1250 x 100 x 90	EBAR30

The standard connections are M10. Other sizes are available upon request.

See Page 25 for the full material specification.

STANDARD : TINNED



DESCRIPTION	DIMENSIONS (mm)	
	L x W x H	
6 WAY EARTH BAR TINNED	300 x 100 x 90	EBAR6/T
8 WAY EARTH BAR TINNED	450 x 100 x 90	EBAR8/T
10 WAY EARTH BAR TINNED	450 x 100 x 90	EBAR10/T
12 WAY EARTH BAR TINNED	520 x 100 x 90	EBAR12/T
14 WAY EARTH BAR TINNED	650 x 100 x 90	EBAR14/T
16 WAY EARTH BAR TINNED	650 x 100 x 90	EBAR16/T
18 WAY EARTH BAR TINNED	800 x 100 x 90	EBAR18/T
20 WAY EARTH BAR TINNED	800 x 100 x 90	EBAR20/T
22 WAY EARTH BAR TINNED	900 x 100 x 90	EBAR22/T
24 WAY EARTH BAR TINNED	1050 x 100 x 90	EBAR24/T
26 WAY EARTH BAR TINNED	1050 x 100 x 90	EBAR26/T
28 WAY EARTH BAR TINNED	1250 x 100 x 90	EBAR28/T
30 WAY EARTH BAR TINNED	1250 x 100 x 90	EBAR30/T

Earth bars are an efficient and convenient way of providing a common earth point.

Kingsmill earth bars are supplied with a powder coated base as standard.

The standard connections are M10. Other sizes are available upon request.

See Page 25 for the full material specification.

SINGLE DISCONNECTING LINK

DESCRIPTION	DIMENSIONS (mm) L x W x H	PART No.
6 WAY EARTH BAR C/W SINGLE DISC. LINK	475 x 100 x 90	EBAR6-1
8 WAY EARTH BAR C/W SINGLE DISC. LINK	575 x 100 x 90	EBAR8-1
10 WAY EARTH BAR C/W SINGLE DISC. LINK	725 x 100 x 90	EBAR10-1
12 WAY EARTH BAR C/W SINGLE DISC. LINK	825 x 100 x 90	EBAR12-1
14 WAY EARTH BAR C/W SINGLE DISC. LINK	925 x 100 x 90	EBAR14-1
16 WAY EARTH BAR C/W SINGLE DISC. LINK	1025 x 100 x 90	EBAR16-1
18 WAY EARTH BAR C/W SINGLE DISC. LINK	1125 x 100 x 90	EBAR18-1
20 WAY EARTH BAR C/W SINGLE DISC. LINK	1275 x 100 x 90	EBAR20-1
22 WAY EARTH BAR C/W SINGLE DISC. LINK	1375 x 100 x 90	EBAR22-1
24 WAY EARTH BAR C/W SINGLE DISC. LINK	1475 x 100 x 90	EBAR24-1
26 WAY EARTH BAR C/W SINGLE DISC. LINK	1575 x 100 x 90	EBAR26-1
28 WAY EARTH BAR C/W SINGLE DISC. LINK	1725 x 100 x 90	EBAR28-1
30 WAY EARTH BAR C/W SINGLE DISC. LINK	1825 x 100 x 90	EBAR30-1



The standard connections are M10. Other sizes are available upon request.

See Page 25 for the full material specification.

SINGLE DISCONNECTING LINK : TINNED

DESCRIPTION	DIMENSIONS (mm) L x W x H	PART No.
6 WAY EARTH BAR TINNED C/W SINGLE DISC. LINK	475 x 100 x 90	EBAR6-1/T
8 WAY EARTH BAR TINNED C/W SINGLE DISC. LINK	575 x 100 x 90	EBAR8-1/T
10 WAY EARTH BAR TINNED C/W SINGLE DISC. LINK	725 x 100 x 90	EBAR10-1/T
12 WAY EARTH BAR TINNED C/W SINGLE DISC. LINK	825 x 100 x 90	EBAR12-1/T
14 WAY EARTH BAR TINNED C/W SINGLE DISC. LINK	925 x 100 x 90	EBAR14-1/T
16 WAY EARTH BAR TINNED C/W SINGLE DISC. LINK	1025 x 100 x 90	EBAR16-1/T
18 WAY EARTH BAR TINNED C/W SINGLE DISC. LINK	1125 x 100 x 90	EBAR18-1/T
20 WAY EARTH BAR TINNED C/W SINGLE DISC. LINK	1275 x 100 x 90	EBAR20-1/T
22 WAY EARTH BAR TINNED C/W SINGLE DISC. LINK	1375 x 100 x 90	EBAR22-1/T
24 WAY EARTH BAR TINNED C/W SINGLE DISC. LINK	1475 x 100 x 90	EBAR24-1/T
26 WAY EARTH BAR TINNED C/W SINGLE DISC. LINK	1575 x 100 x 90	EBAR26-1/T
28 WAY EARTH BAR TINNED C/W SINGLE DISC. LINK	1725 x 100 x 90	EBAR28-1/T
30 WAY EARTH BAR TINNED C/W SINGLE DISC. LINK	1825 x 100 x 90	EBAR30-1/T



The single disconnecting link is mainly used to offer a temporary break in the connection to the earth allowing the inspection and testing of multiple earth rods / systems while disconnected from the lightning and earth system.

Kingsmill earth bars are supplied with a powder coated base as standard.

The standard connections are M10. Other sizes are available upon request.

See Page 25 for the full material specification.

TWIN DISCONNECTING LINK



DESCRIPTION	DIMENSIONS (mm) L x W x H	PART No.
6 WAY EARTH BAR C/W TWIN DISC. LINK	550 x 100 x 90	EBAR6-2
8 WAY EARTH BAR C/W TWIN DISC. LINK	650 x 100 x 90	EBAR8-2
10 WAY EARTH BAR C/W TWIN DISC. LINK	800 x 100 x 90	EBAR10-2
12 WAY EARTH BAR C/W TWIN DISC. LINK	900 x 100 x 90	EBAR12-2
14 WAY EARTH BAR C/W TWIN DISC. LINK	1000 x 100 x 90	EBAR14-2
16 WAY EARTH BAR C/W TWIN DISC. LINK	1100 x 100 x 90	EBAR16-2
18 WAY EARTH BAR C/W TWIN DISC. LINK	1200 x 100 x 90	EBAR18-2
20 WAY EARTH BAR C/W TWIN DISC. LINK	1350 x 100 x 90	EBAR20-2
22 WAY EARTH BAR C/W TWIN DISC. LINK	1450 x 100 x 90	EBAR22-2
24 WAY EARTH BAR C/W TWIN DISC. LINK	1550 x 100 x 90	EBAR24-2
26 WAY EARTH BAR C/W TWIN DISC. LINK	1650 x 100 x 90	EBAR26-2
28 WAY EARTH BAR C/W TWIN DISC. LINK	1800 x 100 x 90	EBAR28-2
30 WAY EARTH BAR C/W TWIN DISC. LINK	1900 x 100 x 90	EBAR30-2

The standard connections are M10. Other sizes are available upon request.

See Page 25 for the full material specification.

TWIN DISCONNECTING LINK : TINNED



DESCRIPTION	DIMENSIONS (mm) L x W x H	PART No.
6 WAY EARTH BAR TINNED C/W TWIN DISC. LINK	550 x 100 x 90	EBAR6-2/T
8 WAY EARTH BAR TINNED C/W TWIN DISC. LINK	650 x 100 x 90	EBAR8-2/T
10 WAY EARTH BAR TINNED C/W TWIN DISC. LINK	800 x 100 x 90	EBAR10-2/T
12 WAY EARTH BAR TINNED C/W TWIN DISC. LINK	900 x 100 x 90	EBAR12-2/T
14 WAY EARTH BAR TINNED C/W TWIN DISC. LINK	1000 x 100 x 90	EBAR14-2/T
16 WAY EARTH BAR TINNED C/W TWIN DISC. LINK	1100 x 100 x 90	EBAR16-2/T
18 WAY EARTH BAR TINNED C/W TWIN DISC. LINK	1200 x 100 x 90	EBAR18-2/T
20 WAY EARTH BAR TINNED C/W TWIN DISC. LINK	1350 x 100 x 90	EBAR20-2/T
22 WAY EARTH BAR TINNED C/W TWIN DISC. LINK	1450 x 100 x 90	EBAR22-2/T
24 WAY EARTH BAR TINNED C/W TWIN DISC. LINK	1550 x 100 x 90	EBAR24-2/T
26 WAY EARTH BAR TINNED C/W TWIN DISC. LINK	1650 x 100 x 90	EBAR26-2/T
28 WAY EARTH BAR TINNED C/W TWIN DISC. LINK	1800 x 100 x 90	EBAR28-2/T
30 WAY EARTH BAR TINNED C/W TWIN DISC. LINK	1900 x 100 x 90	EBAR30-2/T

The twin disconnecting link is mainly used to offer a temporary break in the connection to the earth allowing the inspection and testing of multiple earth rods / systems while disconnected from the lightning and earth system.

Kingsmill earth bars are supplied with a powder coated base as standard.

The standard connections are M10. Other sizes are available upon request.

See Page 25 for the full material specification.

600AMP & 1000 AMP : INCL. TINNED

DESCRIPTION	DIMENSIONS (mm) L x W x H	WEIGHT (Kg)	PART No.
600amp EARTH BAR	285 x 70 x 80	1.30	EBAR600
1000amp EARTH BAR	520 x 90 x 90	3.24	EBAR1000
600amp TINNED EARTH BAR	285 x 70 x 80	1.30	EBAR600/T
1000amp TINNED EARTH BAR	520 x 90 x 90	3.24	EBAR1000/T

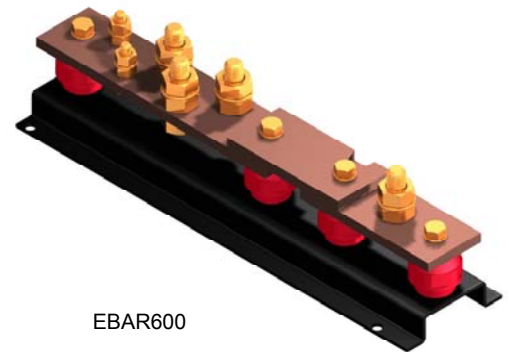

EBAR600

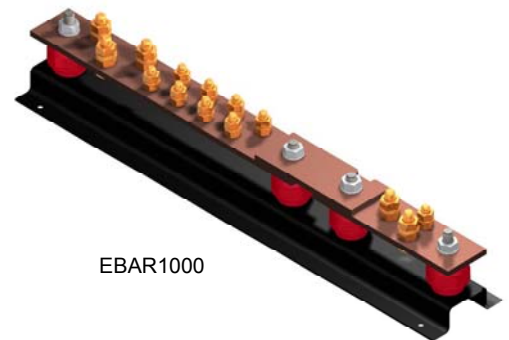

EBAR1000

Earth bars are an efficient and convenient way of providing a common earth point.

Kingsmill earth bars are supplied with a powder coated base as standard.

EBAR600 - 2 x M06 connections, 4 x M10 connections.

EBAR1000 - 9 x M08 connections, 5 x M12 connections.

INSULATORS

DESCRIPTION	SIZE (mm)	WEIGHT (Kg)	PART No.
INSULATOR STAND OFF TYPE C/W 2 STUDS & 3 NUTS	M10 x 35	0.15	INSU1
INSULATOR STAND OFF TYPE	M10 x 35	0.08	INSU2
INSULATOR STAND OFF TYPE	M06 x 25	0.03	INSU3
INSULATOR STAND OFF TYPE	M10 x 51	0.09	INSU4



Electrical:

Dielectric Strength:	>14 Kv/mm
Resistance (normal):	>10 M Ohms
Resistance (bolted):	>10 M Ohms
Arc resistance:	>180 sec.
Tracking index:	>600

Inserts:

Brass	M06	9Nm Torque
	M08	18Nm Torque
	M10	35Nm Torque





MANUFACTURING TO DESIGN SPECIFICATION

Standard earth bars meet most specifications for the majority of applications.

However, you may have a special requirement and we can design and manufacture an earth bar to suit this application. You can send your required specification to us and we will design you a bespoke earth bar which you can check and confirm is correct before placing your order.

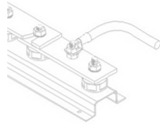
Variables of the earth bar are applied to each component in the earth bar specification including the size and type of bolt, nut & washer, length, width, thickness of bar, number of disconnecting links and their position, the finish of the bar as well as many other variables.

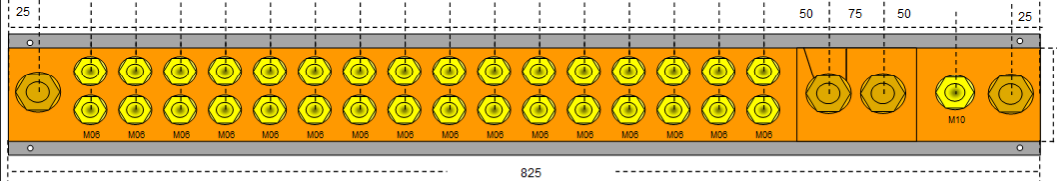
Below is a typical example of where a bespoke earth bar has been designed and then manufactured. In the below instance, the customer wanted a certain amount of fixing terminals, but had limited space to install the earth bar. The fixing terminals were positioned in parallel to reduce the length.

DRW REF:EB-SPEC		RECOMMENDED BASE FIXINGS: 1 1/2 x 10g BRASS C/S SCREW PLASTIC WALL PLUG 8-10g	Supplied on a Standard Earth Bar Base e.g. 
			
			
MATERIAL SPECIFICATION:	BASE: GALVANISED STEEL CHANNEL BASE	 Kingsmill Ind (UK) Ltd. , Unit 4, Plymouth Avenue, Pinxton, Derbyshire, NG16 6NS, Tel: 01773 510001, Fax: 01773 863336 E-Mail: sales@kingsmillearthing.co.uk, Web: www.kingsmillearthing.co.uk	
BAR MATERIAL & SIZE: 50 (W) x 06 (T) HDHC C101	LENGTH: 825		
STUD ASSEMBLY: M06 x 25, M10 x 35 BRASS C/W FLAT WASHER & NUT	FINISH: SELF COLOUR		
CENTRES: 35	SCALE: NTS		
INSULATORS: N/A	QUANTITY: 1		
SHEET NO: 1/1		GENERAL NOTES: 1. All dimensions in mm 2. All dimensions shown are before stated finish 3. All sharp edges removed.	
THIS DRAWING IS THE PROPERTY OF KINGSMILL INDUSTRIES (UK) LTD, AND MAY NOT BE USED FOR ANY PURPOSE OTHER THAN WHICH IT IS SUPPLIED			??/??/2012

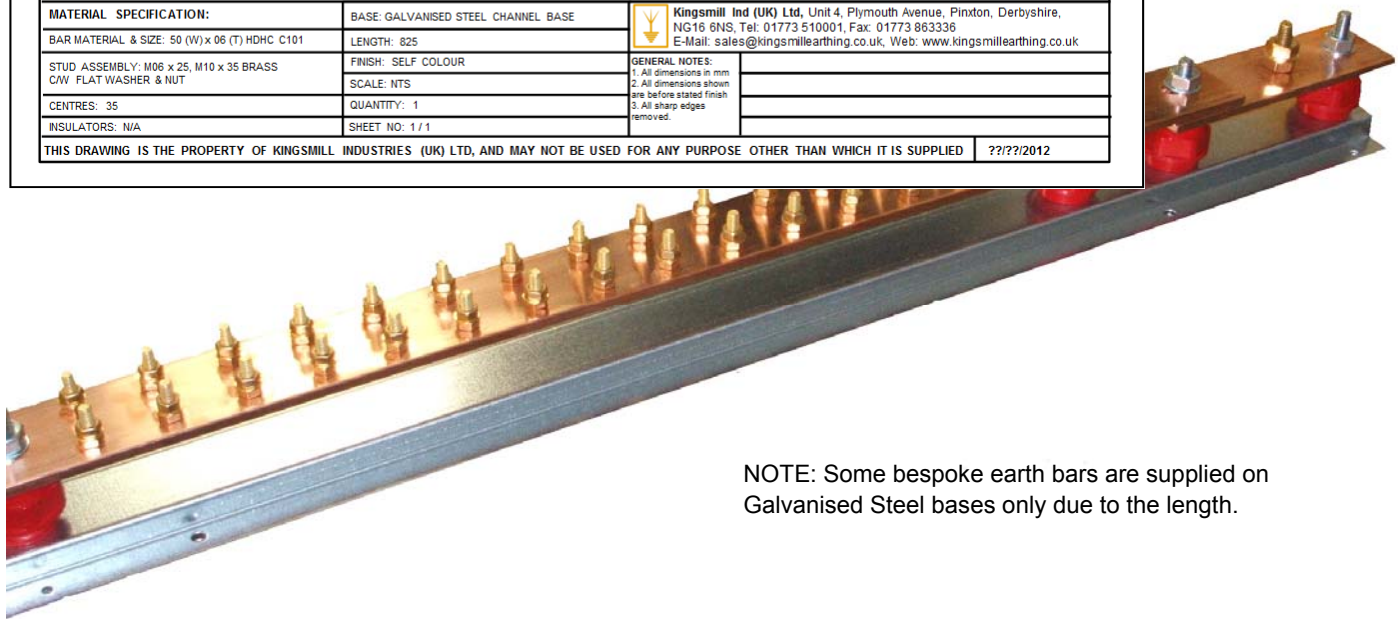

NOTE: Some bespoke earth bars are supplied on Galvanised Steel bases only due to the length.

MANUFACTURING TO DESIGN SPECIFICATION

Please see below further examples of bespoke earth bars that have been manufactured to customer specification.

These bespoke earth bars can be designed and manufactured to the exact customer specification and advice can be given where necessary to ensure you are 100% satisfied with your product.

EXAMPLE i:

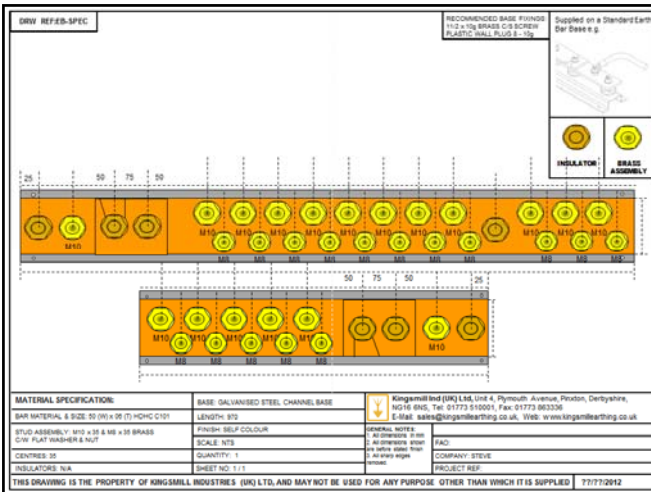

EXAMPLE ii:

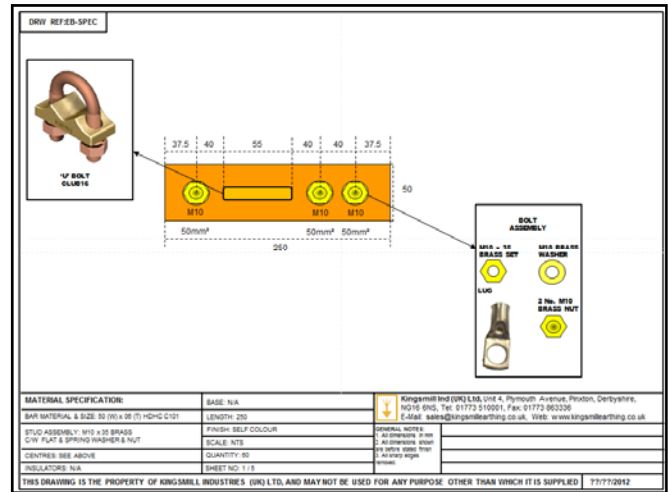

EXAMPLE iii:

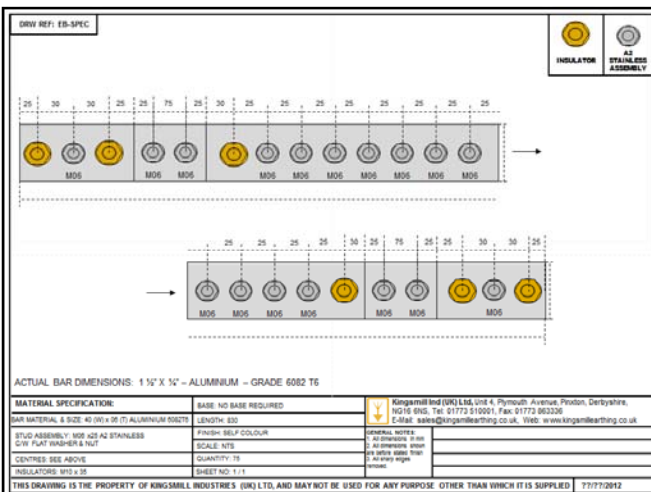

EXAMPLE iv:

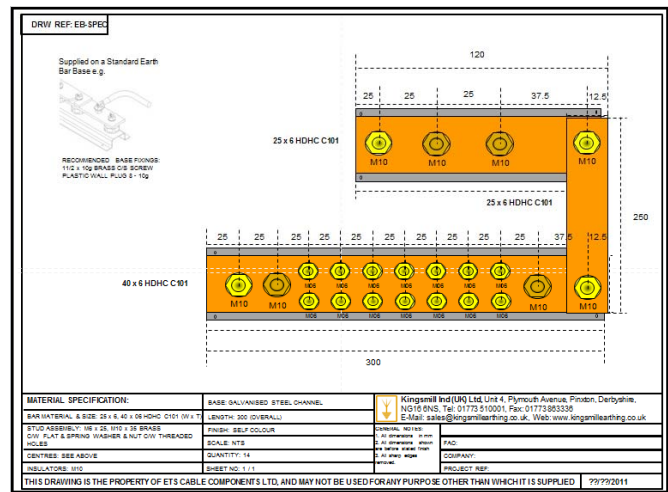

BRASS



Other materials available on request.

DESCRIPTION	SIZE (mm)	WEIGHT (Kg)	PART No.
BRASS HEXAGON SET	M06 x 25	0.006	BHS0625
BRASS HEXAGON SET	M06 x 35	0.007	BHS0635
BRASS HEXAGON SET	M08 x 16	0.007	BHS0816
BRASS HEXAGON SET	M08 x 25	0.008	BHS0825
BRASS HEXAGON SET	M08 x 35	0.009	BHS0835
BRASS HEXAGON SET	M10 x 25	0.02	BHS1025
BRASS HEXAGON SET	M10 x 35	0.03	BHS1035
BRASS HEXAGON SET	M12 x 25	0.03	BHS1225
BRASS HEXAGON SET	M12 x 35	0.05	BHS1235
BRASS FULL NUT	M06	0.002	BFN06
BRASS FULL NUT	M08	0.005	BFN08
BRASS FULL NUT	M10	0.01	BFN10
BRASS FULL NUT	M12	0.016	BFN12
BRASS FLAT WASHER	M06	0.0001	BFW06
BRASS FLAT WASHER	M08	0.001	BFW08
BRASS FLAT WASHER	M10	0.002	BFW10
BRASS FLAT WASHER	M12	0.003	BFW12

STAINLESS STEEL



Other materials available on request.

DESCRIPTION	SIZE (mm)	WEIGHT (Kg)	PART No.
A2 S/S HEX SET	M06 x 16	0.003	A2HS0616
A2 S/S HEX SET	M08 x 25	0.008	A2HS0825
A2 S/S HEX SET	M10 x 12	0.02	A2HS1012
A2 S/S HEX SET	M10 x 16	0.02	A2HS1016
A2 S/S HEX SET	M10 x 25	0.025	A2HS1025
A2 S/S HEX SET	M10 x 35	0.03	A2HS1035
A2 S/S HEX SET	M12 x 30	0.04	A2HS1230
A2 S/S HEX SET	M12 x 40	0.06	A2HS1240
A2 S/S FULL NUT	M06	0.002	A2FN06
A2 S/S FULL NUT	M08	0.005	A2FN08
A2 S/S FULL NUT	M10	0.01	A2FN10
A2 S/S FULL NUT	M12	0.016	A2FN12
A2 S/S FLAT WASHER	M06	0.0001	A2FW06
A2 S/S FLAT WASHER	M08	0.001	A2FW08
A2 S/S FLAT WASHER	M10	0.002	A2FW10
A2 S/S FLAT WASHER	M12	0.003	A2FW12
A2 S/S SPRING WASHER	M06	0.0001	A2SPW06
A2 S/S SPRING WASHER	M08	0.001	A2SPW08
A2 S/S SPRING WASHER	M10	0.002	A2SPW10
A2 S/S SPRING WASHER	M12	0.003	A2SPW12

PHOSPHOR BRONZE

DESCRIPTION	SIZE (mm)	WEIGHT (Kg)	PART No.
P.B. HEX SET'S	M10 x 25	0.03	PBHS1025
P.B. HEX SET'S	M10 x 35	0.03	PBHS1035
P.B. HEX SET'S	M12 x 25	0.03	PBHS1225
P.B. HEX SET'S	M12 x 35	0.04	PBHS1235
P.B. FULL NUT	M10	0.01	PBFN10
P.B. FULL NUT	M12	0.02	PBFN12
P.B. FLAT WASHER	M10	0.0025	PBFW10
P.B. FLAT WASHER	M12	0.02	PBFW12
P.B. SPRING WASHER	M10	0.002	PBSPW10
P.B. SPRING WASHER	M12	0.0025	PBSPW12



BRIGHT ZINC PLATED

DESCRIPTION	SIZE (mm)	WEIGHT (Kg)	PART No.
BZP HEX SET	M06 x 25	0.006	BZPHS0625
BZP HEX SET	M08 x 25	0.008	BZPHS0825
BZP HEX SET	M10 x 35	0.03	BZPHS1035
BZP FULL NUT	M06	0.002	BZPFN06
BZP FULL NUT	M08	0.005	BZPFN08
BZP FULL NUT	M10	0.01	BZPFN10
BZP FULL NUT	M12	0.016	BZPFN12
BZP FLAT WASHER	M06	0.0001	BZPFW06
BZP FLAT WASHER	M08	0.001	BZPFW08
BZP FLAT WASHER	M10	0.002	BZPFW10
BZP FLAT WASHER	M12	0.003	BZPFW12
BZP SPRING WASHER	M06	0.0001	BZPSPW06
BZP SPRING WASHER	M08	0.001	BZPSPW08
BZP SPRING WASHER	M10	0.002	BZPSPW10
BZP SPRING WASHER	M12	0.003	BZPSPW12



SCREWS & PLUGS

DESCRIPTION	SIZE (in)	WEIGHT (Kg) PER 100	PART No.
BRASS C/S WOODSCREW	1 1/2 x 10g	0.50	BCSW1.5-10
BRASS C/S WOODSCREW	1 1/2 x 12g	0.60	BCSW1.5-12
CSK SLT ST/ST SCREWS	1 x 10g	0.60	A2CSKSLT101
CSK SLT ST/ST SCREWS	1.5 x 10g	0.60	A2CSKSLT1.5-10
PLASTIC WALL PLUG (RED) 8 - 10g	No.10	0.06	PP-10
PLASTIC WALL PLUG (BROWN) 10-12g	No.12	0.06	PP-12



Other materials available on request.

INTRODUCTION







An integral part of the earthing & lightning protection system is the actual conductor.

Kingsmill Industries (UK) Ltd offer a comprehensive range of copper and aluminium conductors in each of the main world standard formats, i.e. flat tape, solid circular and stranded.

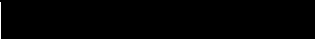
Conductor Colour Chart:

The decision to be made on the colour of PVC covered conductor is governed by the aesthetics of the building to be protected. In order to reduce the impact of an external system, Kingsmill offers a range of colours that have been designed to match the colours of common building materials.

* PVC COLOURS TO BS 5252

COLOUR	STANDARDS	COLOUR
BLACK	18B29*	
GREEN	BS 6746C	
GREY	00A07*	
STONE	08B23*	
WHITE	10B15*	
BROWN	06C39*	
GREEN / YELLOW	N/A	

OTHER COLOURS AVAILABLE UPON REQUEST - PLEASE SPEAK TO A MEMBER OF THE SALES OFFICE.

Copper Conductor Ratings: Fault Current

The following conductor ratings are based upon the recommendations of BS 7430 with an initial conductor temperature of 30°C and a maximum temperature of 250°C.

COND.SIZE	C.S.A. (mm ²)	kA FOR 1 sec.	kA FOR 3 sec.
12.5 x 1.5	18.75	3.3	1.9
12.5 x 3	37.50	6.6	3.8
20 x 1.5	30.00	5.3	3.0
20 x 3	60.00	10.6	6.1
25 x 1.5	37.50	6.6	3.8
25 x 3	75.00	13.2	7.6
25 x 4	100	17.6	10.2
25 x 6	150	26.4	15.2
30 x 2	60.00	10.6	6.1
30 x 3	90.00	15.8	9.1
30 x 4	120	21.1	12.2
30 x 5	150	26.4	15.2
31 x 3	93.00	16.4	9.5

COND.SIZE	C.S.A. (mm ²)	kA FOR 1 sec.	kA FOR 3 sec.
31 x 6	186	32.7	18.9
38 x 3	114	20.1	11.6
38 x 5	190	33.4	19.3
38 x 6	228	40.1	23.2
40 x 3	120	21.1	12.2
40 x 4	160	28.2	16.3
40 x 5	200	35.2	20.3
40 x 6	240	42.2	24.4
50 x 3	150	26.4	15.2
50 x 4	200	35.2	20.3
50 x 5	250	44.0	25.4
50 x 6	300	52.8	30.5

COPPER TAPE : BARE

COND.SIZE (Y x X) (mm)	C.S.A. (mm ²)	COIL SIZE (m)	WEIGHT (Kg / m)	PART No.
12.5 x 1.5	18.75	100	0.17	CTBA1215
12.5 x 3	37.50	100	0.33	CTBA1230
20 x 1.5	30.00	100	0.27	CTBA2015
20 x 3	60.00	100	0.53	CTBA2030
25 x 1.5	37.50	100	0.33	CTBA2515
25 x 3	75.00	25 or 50	0.67	CTBA2530
25 x 4	100	50	0.89	CTBA2540
25 x 6	150	40	1.34	CTBA2560
30 x 2	60.00	50	0.53	CTBA3020
30 x 3	90.00	50	0.80	CTBA3030
30 x 4	120	40	1.07	CTBA3040
30 x 5	150	40	1.33	CTBA3050
31 x 3	93.00	50	0.83	CTBA3130
31 x 6	186	30	1.65	CTBA3160
38 x 3	114	50	1.01	CTBA3830
38 x 5	190	30	1.69	CTBA3850
38 x 6	228	25	2.03	CTBA3860
40 x 3	120	40	1.06	CTBA4030
40 x 4	160	30	1.42	CTBA4040
40 x 5	200	25	1.78	CTBA4050
40 x 6	240	25	2.13	CTBA4060
50 x 3	150	40	1.33	CTBA5030
50 x 4	200	30	1.78	CTBA5040
50 x 5	250	20	2.22	CTBA5050
50 x 6	300	20	2.68	CTBA5060

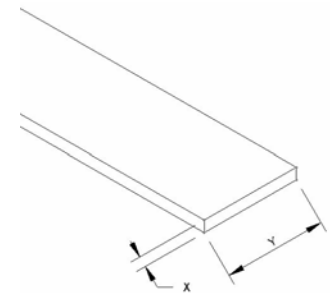

Kingsmill copper tape is embossed 'Kingsmill (UK)' for identification purposes and is manufactured from high conductivity annealed copper.

Material: Copper to BS EN 13601 (formerly BS 1432).

 **BS EN 50164-2 : 2008.**

All bare copper tape sold in the specified coil lengths only.

However, CTBA2530 can be cut to desired length, please speak to the sales office for further details. Please reference the Part No. CTBA2530/DRUM.

COPPER TAPE : PVC COVERED

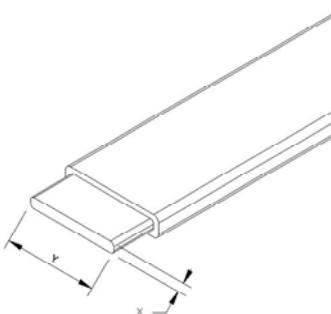
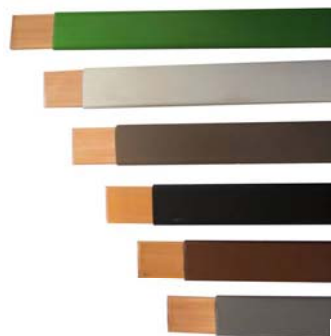

COND.SIZE (Y x X) (mm)	COLOUR	COIL SIZE (m)	WEIGHT (Kg / m)	PART No.
25 x 3	BLACK	25	0.78	TCBL253
25 x 3	BROWN	25	0.78	TCBN253
25 x 3	GREEN	25	0.78	TCGN253
25 x 3	GREY	25	0.78	TCGY253
25 x 3	STONE	25	0.78	TCST253
25 x 3	WHITE	25	0.78	TCWH253
25 x 6	GREEN	40	1.53	TCGN256
50 x 6	GREEN	20	2.96	TCGN506

Kingsmill offers a wide range of UV-stabilised PVC covered tapes in a range of different colours. These colours have been chosen to match the most common structural materials and will reduce the visual impact of a lightning protection conductor.

Material: Copper to BS EN 13601 (formerly BS 1432)
TESTED *PVC Colours to BS 5252 , Green to BS 6746

All PVC tape sold in the specified coil lengths only.

COLOUR	STANDARDS	COLOUR
BLACK	18B29*	
GREEN	BS 6746C	
GREY	00A07*	
STONE	08B23*	
WHITE	10B15*	
BROWN	06C39*	

OTHER COLOURS AVAILABLE UPON REQUEST - PLEASE SPEAK TO A MEMBER OF THE SALES OFFICE.

COPPER TAPE : GREEN / YELLOW COVERED

COND.SIZE (Y x X) (mm)	COLOUR	COIL SIZE (m)	WEIGHT (Kg / m)	PART No.
25 x 3	GREEN / YELLOW	25	0.78	TCGN/Y253

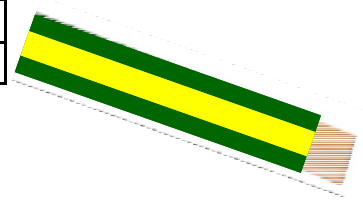

Material: Copper to BS EN 13601 (formerly BS 1432).

PVC Colours to BS 5252 .

All PVC tape sold in the specified coil lengths only.

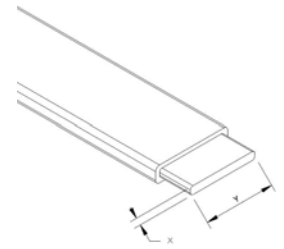

COPPER TAPE : LEAD COVERED

COND.SIZE (Y x X) (mm)	C.S.A. (mm ²)	COIL SIZE (m)	WEIGHT (Kg / m)	PART No.
25 x 3	75	25	2.56	TCLD253

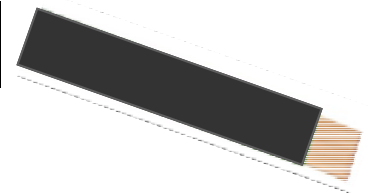

Material: Copper to BS EN 13601 (formerly BS 1432).

All lead tape sold in the specified coil lengths only.

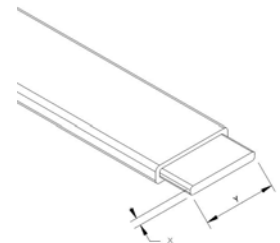

COPPER TAPE : LSOH (LOW SMOKE, ZERO HALOGEN) COVERED

COND.SIZE (Y x X) (mm)	COLOUR	COIL SIZE (m)	WEIGHT (Kg / m)	PART No.
25 x 3	GREEN	25	0.77	TCGN253LS
25 x 3	GREEN	50	0.77	TCGN253LS/50
25 x 6	GREEN	40	1.53	TCGN256LS
50 x 6	GREEN	20	2.95	TCGN506LS

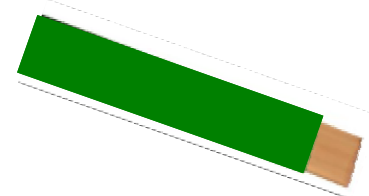

Material: Copper to BS EN 13601 (formerly BS 1432).

PVC Colours to BS 6476C.

All PVC tape sold in the specified coil lengths only.

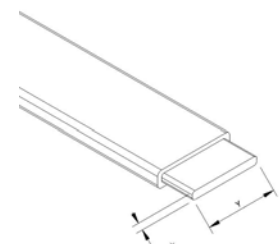

COPPER TAPE : TINNED

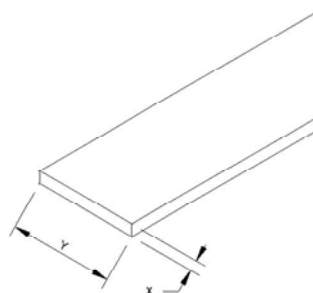

COND.SIZE (Y x X) (mm)	C.S.A. (mm ²)	COIL SIZE (m)	WEIGHT (Kg / m)	PART No.
12.5 x 1.5	18.75	100	0.17	TCTD1215
12.5 x 3	37.50	100	0.33	TCTD1230
20 x 1.5	30.00	100	0.27	TCTD2015
20 x 3	60.00	100	0.53	TCTD2030
25 x 1.5	37.50	100	0.33	TCTD2515
25 x 3	75.00	25 or 50	0.67	TCTD2530
25 x 4	100	50	0.89	TCTD2540
25 x 6	150	40	1.34	TCTD2560
30 x 2	60.00	50	0.53	TCTD3020
30 x 3	90.00	50	0.80	TCTD3030
30 x 4	120	40	1.07	TCTD3040
30 x 5	150	40	1.33	TCTD3050
31 x 3	93.00	50	0.83	TCTD3130
31 x 6	186	30	1.65	TCTD3160
38 x 3	114	50	1.01	TCTD3830
38 x 5	190	30	1.69	TCTD3850
38 x 6	228	25	2.03	TCTD3860
40 x 3	120	40	1.06	TCTD4030
40 x 4	160	30	1.42	TCTD4040
40 x 5	200	25	1.78	TCTD4050
40 x 6	240	25	2.13	TCTD4060
50 x 3	150	40	1.33	TCTD5030
50 x 4	200	30	1.78	TCTD5040
50 x 5	250	20	2.22	TCTD5050
50 x 6	300	20	2.68	TCTD5060

Kingsmill tinned copper tape is embossed 'Kingsmill (UK)' for identification purposes and is manufactured from high conductivity annealed copper.



Material: Copper tinned to BS EN 13601 (formerly BS 1432).

All tinned copper tape sold in the specified coil lengths only.

COPPER BAR : PLAIN

COND.SIZE (Y x X) (mm)	C.S.A. (mm ²)	BAR LENGTH (m)	WEIGHT (Kg / m)	PART No.
25 x 3	75	2.0	0.67	CBHD2530
25 x 6	150	2.0	1.34	CBHD2560
31 x 3	93	2.0	0.83	CBHD3130
38 x 3	114	2.0	1.01	CBHD3830
38 x 6	228	2.0	2.03	CBHD3860
50 x 6	300	2.0	2.67	CBHD5060
50 x 10	500	2.0	4.45	CBHD5010
60 x 6	600	2.0	3.20	CBHD6060
75 x 6	450	2.0	4.00	CBHD7506
100 x 6	600	2.0	5.34	CBHD1006

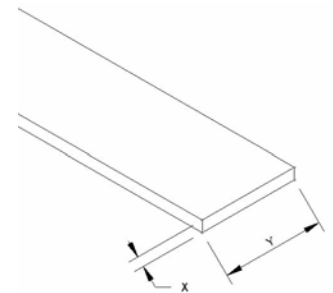

TESTED Material: Copper to BS EN 12163.

Other sizes are available on request.

Other length's are available on request.

COPPER BAR : TINNED

COND.SIZE (Y x X) (mm)	C.S.A. (mm ²)	BAR LENGTH (m)	WEIGHT (Kg / m)	PART No.
25 x 3	75	2.0	0.67	CBHD2530/T
25 x 6	150	2.0	1.34	CBHD2560/T
50 x 6	300	2.0	2.67	CBHD5060/T

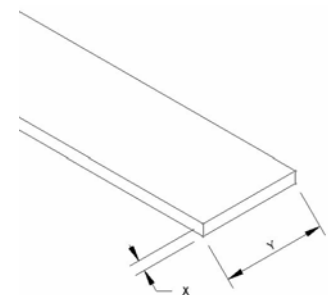

TESTED Material: Copper to BS EN 12163.

Other sizes are available on request.

Other length's are available on request.

FLEXIBLE FLAT COPPER BRAID : PLAIN

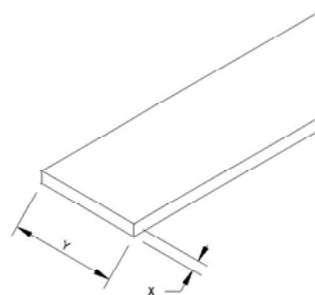

OVERALL NOMINAL	C.S.A. (mm ²)	WEIGHT	PART No.
12 x 1.0	6.0	0.055	FCB1201
15 x 1.5	10	0.096	FCB1515
19 x 2.5	16	0.16	FCB1925
25 x 3.0	25	0.25	FCB2530
25 x 3.5	35	0.34	FCB2535
30 x 5.0	50	0.49	FCB3050
32 x 6.0	70	0.63	FCB3260
37 x 6.0	95	0.93	FCB3760
45 x 6.0	120	1.15	FCB4560
50 x 8.0	150	1.45	FCB5080

Kingsmill flexible flat copper braid (plain) is suitable for applications of earth bonding.

The braid can also be supplied as standard pre-cut and drilled braid bonds (see pages 22-23).



Material: Copper wire to BS EN 13602.

Other sizes and types of braid can be made to order. Please contact the sales office for further details.

CIRCULAR BRAID ALSO AVAILABLE IN BOTH PLAIN AND TINNED - PLEASE CONTACT THE SALES OFFICE FOR FURTHER DETAILS



CIRCULAR ALSO AVAILABLE
UPON REQUEST

FLEXIBLE FLAT COPPER BRAID : TINNED

OVERALL NOMINAL SIZE (Y x X) (mm)	C.S.A. (mm ²)	WEIGHT (Kg / m)	PART No.
12 x 1.0	6.0	0.055	FCBT1201
15 x 1.5	10	0.096	FCBT1515
19 x 2.5	16	0.16	FCBT1925
25 x 3.0	25	0.25	FCBT2530
25 x 3.5	35	0.34	FCBT2535
30 x 5.0	50	0.49	FCBT3050
32 x 6.0	70	0.63	FCBT3260
37 x 6.0	95	0.93	FCBT3760
45 x 6.0	120	1.15	FCBT4560
50 x 8.0	150	1.45	FCBT5080

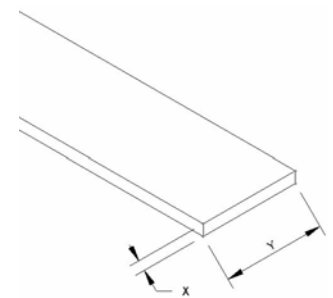

Kingsmill flexible flat copper braid (tinned) is suitable for applications of earth bonding.

The braid can also be supplied as standard pre-cut and drilled braid bonds (see pages 22-23).

 **Material: Tinned copper wire to BS EN 13602.**

Other sizes and types of braid can be made to order. Please contact the sales office for further details.

CIRCULAR BRAID ALSO AVAILABLE IN BOTH PLAIN AND TINNED - PLEASE CONTACT THE SALES OFFICE FOR FURTHER DETAILS

CIRCULAR ALSO AVAILABLE
UPON REQUEST



ALUMINIUM : BARE

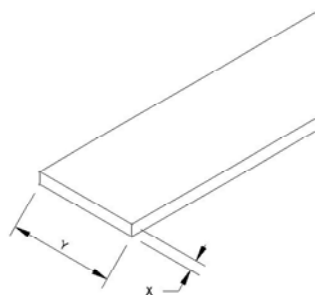

OVERALL NOMINAL SIZE (Y x X) (mm)	COIL SIZE (m)	WEIGHT (Kg / m)	PART No.
12.5 x 1.5	50	0.05	ATBA12515
20 x 3	50	0.17	ATBA2030
25 x 3	50	0.21	ATBA2530
30 x 3	50	0.25	ATBA3030
25 x 6	50	0.42	ATBA2560
40 x 6	50	0.67	ATBA4060
50 x 6	50	0.85	ATBA5060

TESTED Material: Aluminium tape to BS EN 755-5.

All aluminium tape sold in the specified coil lengths only.

ALUMINIUM : PVC COVERED

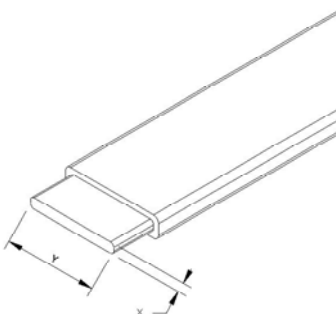
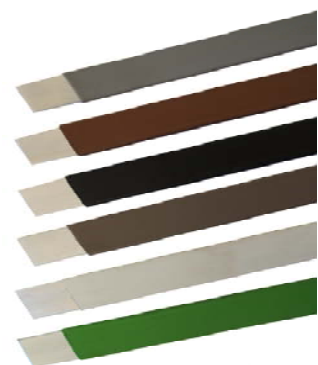

OVERALL NOMINAL SIZE (Y x X) (mm)	COLOUR	COIL SIZE (m)	WEIGHT (Kg / m)	PART No.
12.5 x 1.5	BLACK	50	0.09	TABL12515
20 x 3	BLACK	50	0.25	TABL2030
25 x 3	BLACK	50	0.31	TABL253
25 x 3	BROWN	50	0.31	TABN253
25 x 3	GREEN	50	0.31	TAGN253
25 x 3	GREY	50	0.31	TAGY253
25 x 3	STONE	50	0.31	TAST253
25 x 3	WHITE	50	0.31	TAWH253

Kingsmill offers a wide range of UV-stabilised PVC covered tapes in a range of different colours. These colours have been chosen to match the most common structural materials and will reduce the visual impact of a lightning protection conductor.

TESTED Material: Aluminium tape to BS EN 755-5.
PVC Colours to BS 5252 , Green to BS 6746

All PVC tape sold in the specified coil lengths only.

SOLID CIRCULAR COPPER : BARE

DIAMETER (X) (mm)	COIL SIZE (m)	WEIGHT (Kg /	PART No.
8.0	50	0.44	CC08



TESTED Material: Copper conductor to BS EN 13601 (formerly BS 1433).

All circular copper sold in the specified coil lengths only.

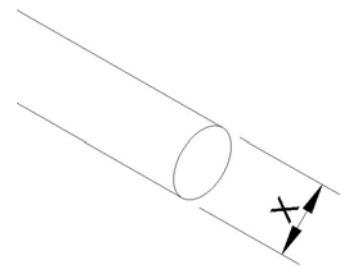

SOLID CIRCULAR COPPER : PVC COVERED

DIAMETER (X) (mm)	COLOUR	COIL SIZE (m)	WEIGHT (Kg / m)	PART No.
8.0	BLACK	50	0.49	CCBL
8.0	BROWN	50	0.49	CCBN
8.0	GREY	50	0.49	CCGY
8.0	STONE	50	0.49	CCST
8.0	WHITE	50	0.49	CCWH



Kingsmill offers a wide range of UV-stabilised PVC covered circular conductor in a range of different colours. These colours have been chosen to match the most common structural materials and will reduce the visual impact of a lightning protection conductor.

'Y' is the conductor diameter including the PVC sheathing - 10mm.

TESTED Material: Copper conductor to BS EN 13601 (formerly BS 1433).
TESTED PVC Colours to BS 5252

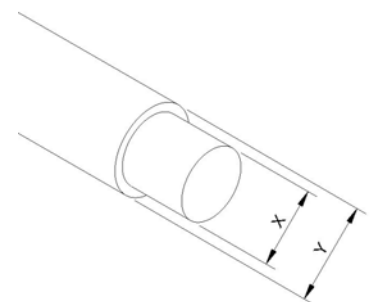

All PVC circular sold in the specified coil lengths only.

SOLID CIRCULAR ALUMINIUM : BARE

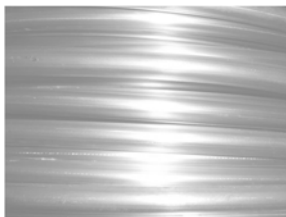

DIAMETER (X) (mm)	COIL SIZE (m)	WEIGHT (Kg / m)	PART No.
8.0	50	0.12	CA08

TESTED Material: Aluminium conductor to BS EN 755-5.

All circular aluminium sold in the specified coil lengths only.

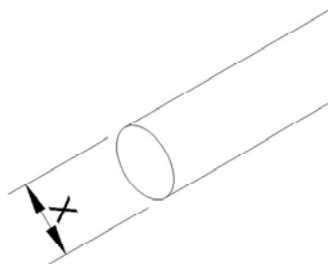

SOLID CIRCULAR ALUMINIUM : PVC COVERED



DIAMETER (X) (mm)	COLOUR	COIL SIZE (m)	WEIGHT (Kg / m)	PART No.
8.0	BLACK	50	0.18	CABL
8.0	BROWN	50	0.18	CABN
8.0	GREY	50	0.18	CAGY
8.0	STONE	50	0.18	CAST
8.0	WHITE	50	0.18	CAWH

Kingsmill offers a wide range of UV-stabilised PVC covered circular conductor in a range of different colours. These colours have been chosen to match the most common structural materials and will reduce the visual impact of a lightning protection conductor.

'Y' is the conductor diameter including the PVC sheathing - 10mm.

TESTED Material: Aluminium to BS EN 755-5.

TESTED PVC Colours to BS 5252

All PVC circular sold in the specified coil lengths only.

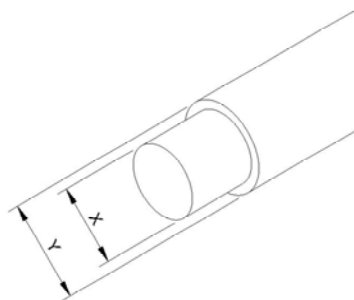

COPPER CABLE : BARE STRANDED

C.S.A (mm ²)	STRANDING No. / DIA (mm) **	NOMINAL DIAMETER (mm)	WEIGHT (Kg / m)	PART No.
6.0	7 / 1.04	3.12	0.05	BSCW006
16	7 / 1.70	5.10	0.15	BSCW016
25	7 / 2.14	6.42	0.23	BSCW025
35	7 / 2.52	7.56	0.32	BSCW035
50	19 / 1.78	8.90	0.43	BSCW050
70	19 / 2.14	10.70	0.62	BSCW070
95	19 / 2.52	12.60	0.86	BSCW095
120	37 / 2.03	14.21	1.09	BSCW120
150	37 / 2.25	15.75	1.33	BSCW150
185	37 / 2.52	17.64	1.67	BSCW185
240	61 / 2.25	20.25	2.20	BSCW240
300	61 / 2.52	22.68	2.76	BSCW300
400	61 / 2.85	25.65	3.53	BSCW400

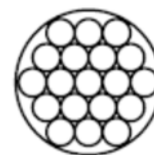

ILLUSTRATION
PURPOSES ONLY

 **Material: Soft drawn stranded copper cable to BS EN 60228.**

** Stranding may vary.

COPPER CABLE : GREEN / YELLOW PVC COVERED

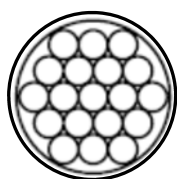
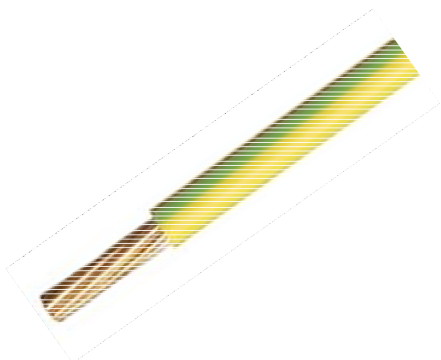

ILLUSTRATION
PURPOSES ONLY

C.S.A (mm ²)	STRANDING No. / DIA (mm) **	WEIGHT (Kg / m)	PART No.
16	7 / 1.70	0.15	CCGY016
25	7 / 2.14	0.23	CCGY025
35	7 / 2.52	0.32	CCGY035
50	19 / 1.78	0.43	CCGY050
70	19 / 2.14	0.62	CCGY070
95	19 / 2.52	0.86	CCGY095
120	37 / 2.03	1.09	CCGY120
150	37 / 2.25	1.33	CCGY150
185	37 / 2.52	1.67	CCGY185
240	61 / 2.25	2.20	CCGY240
300	61 / 2.52	2.76	CCGY300
400	61 / 2.85	3.53	CCGY400

Material: Soft drawn stranded copper cable to BS EN 60228.



PVC Colours to BS 5252

** Stranding may vary.

COPPER CABLE : TINNED STRANDED

C.S.A (mm ²)	STRANDING No. / DIA. (mm) **	WEIGHT (Kg / m)	PART No.
16	7 / 1.70	0.15	BSCW016/T
25	7 / 2.14	0.23	BSCW025/T
35	7 / 2.52	0.32	BSCW035/T
50	19 / 1.78	0.43	BSCW050/T
70	19 / 2.14	0.62	BSCW070/T
95	19 / 2.52	0.86	BSCW095/T
120	37 / 2.03	1.09	BSCW120/T
150	37 / 2.25	1.33	BSCW150/T
185	37 / 2.52	1.67	BSCW185/T
240	61 / 2.25	2.20	BSCW240/T
300	61 / 2.52	2.76	BSCW300/T
400	61 / 2.85	3.53	BSCW400/T

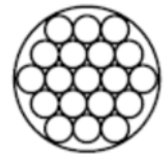
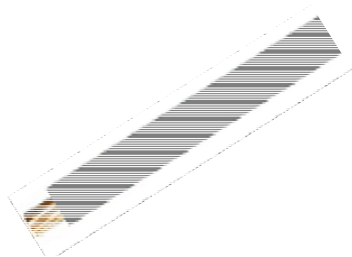

ILLUSTRATION
PURPOSES ONLY

 **Material: Tinned soft drawn stranded copper cable to BS EN 60228.**

** Stranding may vary.

COPPER CABLE : LEAD COVERED STRANDED



C.S.A (mm ²)	STRANDING No. / DIA. (mm)	WEIGHT (Kg / m)	PART No.
185	37 / 2.52	1.67	BSCW185/LS
240	61 / 2.25	2.20	BSCW240/LS
300	61 / 2.52	2.76	BSCW300/LS
400	61 / 2.85	3.53	BSCW400/LS

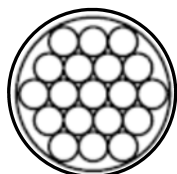

2mm Radial thickness, chemical B lead.



Material: Soft drawn stranded copper cable to BS EN 60228.

ILLUSTRATION
PURPOSES ONLY

TAPE GUARDS / CABLE GUARDS



LENGTH (mm)	WIDTH (mm)	DEPTH (mm)	WEIGHT (Kg)	PART No.
2500	90	15	2.50	GAVG

Kingsmill Steel guards provide protection from accidental damage, vandalism and theft. Suitable for 25 x 3 tape (including fixing clip).

Easy to fix, the guard has a low profile and a galvanised finish giving this product a long lasting resistance to corrosion.

Material: Galvanised Steel.

LENGTH (mm)	CONDUCTOR SIZE (mm)	COLOUR	WEIGHT (Kg)	PART No.
3000	25 x 3, 8 (Dia.), 50sq ²	BROWN	1.00	P-GUA-BN
3000	25 x 3, 8 (Dia.), 50sq ²	BLACK	1.00	P-GUA-BL
3000	25 x 3, 8 (Dia.), 50sq ²	GREY	1.00	P-GUA-GY
3000	25 x 3, 8 (Dia.), 50sq ²	WHITE	1.00	P-GUA-WH
3000	25 x 3, 8 (Dia.), 50sq ²	STONE	1.00	P-GUA-ST

Kingsmill plastic tape / cable guards provide protection from accidental damage, vandalism and theft. Suitable for 25 x 3 tape & cables up to 50sqmm² (or 8mm Dia.).

Material: High density plastic.

METALLIC DC TAPE CLIPS : FLAT / CIRCULAR CONDUCTOR

CONDUCTOR SIZE (mm)	CONDUCTOR TYPE	WEIGHT (Kg)	PART No.
20 x 3	BARE COPPER	0.07	MDC203
25 x 3	BARE COPPER	0.08	MDC253
25 x 4	BARE COPPER	0.07	MDC254
25 x 6	BARE COPPER	0.10	MDC256
31 x 3	BARE COPPER	0.09	MDC313
31 x 6	BARE COPPER	0.11	MDC316
38 x 3	BARE COPPER	0.12	MDC383
38 x 5	BARE COPPER	0.12	MDC385
38 x 6	BARE COPPER	0.14	MDC386
40 x 4	BARE COPPER	0.14	MDC404
40 x 6	BARE COPPER	0.14	MDC406
50 x 3	BARE COPPER	0.15	MDC503
50 x 4	BARE COPPER	0.15	MDC504
50 x 6	BARE COPPER	0.17	MDC506
25 x 3	PVC COPPER	0.13	MDC253P
25 x 6	PVC COPPER	0.10	MDC256P
50 x 6	PVC COPPER	0.26	MDC506P
25 x 3	LEAD COVERED COPPER	0.20	MDC253LD
20 x 3	BARE ALUMINIUM	0.02	MDA203
25 x 3	BARE ALUMINIUM	0.03	MDA253
25 x 6	BARE ALUMINIUM	0.04	MDA256
50 x 6	BARE ALUMINIUM	0.05	MDA506
25 x 3	PVC ALUMINIUM	0.04	MDA253P
50 x 6	PVC ALUMINIUM	0.06	MDA506P
50 ²	BARE COPPER	0.10	HDCS50
70 ²	BARE COPPER	0.10	HDCS70
95 ²	BARE COPPER	0.10	HDCS95
8 DIA.	BARE COPPER	0.10	HDCS08



MDC253



HDCS70

Material: Gunmetal / aluminium alloys.

 BS EN 62561-4

NON METALLIC DC CLIPS : FLAT CONDUCTOR



CONDUCTOR SIZE (mm)	CONDUCTOR TYPE	COLOUR	WEIGHT (Kg)	PART No.
20 x 3	BARE	BROWN	0.01	PCBN203B
20 x 3	BARE	GREY	0.01	PCGY203B
25 x 3	BARE	BROWN	0.01	PCBN253B
25 x 3	BARE	GREY	0.01	PCGY253B
50 x 6	BARE	BROWN	0.01	PCBN506B
25 x 3	PVC	BROWN	0.01	PCBN253P
25 x 3	PVC	BLACK	0.01	PCBL253P
25 x 3	PVC	GREY	0.01	PCGY253P
25 x 3	PVC	GREEN	0.01	PCGN253P
25 x 3	PVC	STONE	0.01	PCST253P
25 x 3	PVC	WHITE	0.01	PCWH253P

Kingsmill non-metallic DC clips are available in six colours to match bare and PVC copper and aluminium tapes.

Material: Polypropylene.

NON METALLIC DC CLIPS : CIRCULAR : PUSH IN TYPE

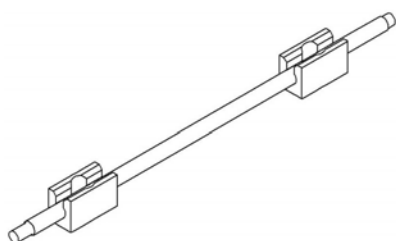

CONDUCTOR DIA. (mm)	CONDUCTOR TYPE	COLOUR	WEIGHT (Kg)	PART No.
8.0	BARE	BROWN	0.01	PCBN08B
8.0	BARE	GREY	0.01	PCGY08B
8.0	PVC	BROWN	0.01	PCBN08P
8.0	PVC	GREY	0.01	PCGY08P
8.0	PVC	BLACK	0.01	PCBL08P
8.0	PVC	STONE	0.01	PCST08P
8.0	PVC	WHITE	0.01	PCWH08P

Kingsmill one piece push in clips are designed for ease of installation to suit 8mm bare and PVC sheathed circular conductors.

Push in clips are UV stabilised to prevent degradation in cold weather conditions.

Material: Polypropylene.

NON METALLIC DC CLIPS : CIRCULAR : WRAP OVER TYPE

CONDUCTOR DIA (mm)	CONDUCTOR TYPE	COLOUR	WEIGHT (Kg)	PART No.
8.0	BARE	BROWN	0.01	PCBN08B/BUTT
8.0	BARE	GREY	0.01	PCGY08B/BUTT
8.0	PVC	BROWN	0.01	PCBN08P/BUTT
8.0	PVC	GREY	0.01	PCGY08P/BUTT
8.0	PVC	BLACK	0.01	PCBL08P/BUTT
8.0	PVC	STONE	0.01	PCST08P/BUTT
8.0	PVC	WHITE	0.01	PCWH08P/BUTT

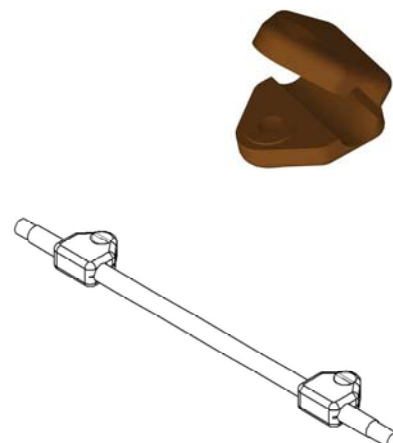

Kingsmill wrap over type clips are designed for ease of installation to suit 8mm bare and PVC sheathed circular conductors.

Material: Polypropylene.

SLATE HOLD FAST : FLAT CONDUCTOR

CONDUCTOR SIZE (mm)	CONDUCTOR TYPE	COLOUR	WEIGHT (Kg)	PART No.
25 x 3	BARE	BROWN	0.05	SHBN253B
25 x 3	BARE	GREY	0.05	SHGY253B
25 x 3	PVC	BROWN	0.05	SHBN253P
25 x 3	PVC	GREY	0.05	SHGY253P
25 x 3	PVC	BLACK	0.05	SHBL253P
25 x 3	PVC	STONE	0.05	SHST253P
25 x 3	PVC	GREEN	0.05	SHGN253P
25 x 3	PVC	WHITE	0.05	SHWH253P

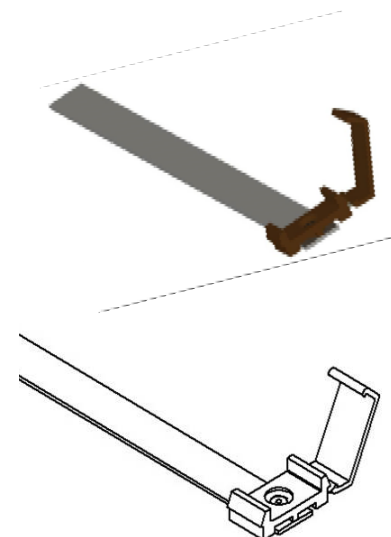

Kingsmill slate holdfasts are used for the installation of conductor tape above the roof tiles without drilling holes. The aluminium tail slides under the roof tile and is fixed to the wooden beam or tile batten using proprietary galvanised nails, the clip then protrudes from the tile and offers a fixing for the tape.

Material: Polypropylene.

Aluminium tape to BS EN 755-5

ONE HOLE CABLE CLIP : CIRCULAR CONDUCTOR

CONDUCTOR DIA (mm)	CONDUCTOR TYPE	WEIGHT (Kg)	PART No.
8.0	COPPER	0.01	OH8C
8.0	ALUMINIUM	0.01	OH8A
8.0	COPPER PVC COVERED	0.01	OH10C
8.0	ALUMINIUM PVC COVERED	0.01	OH10A

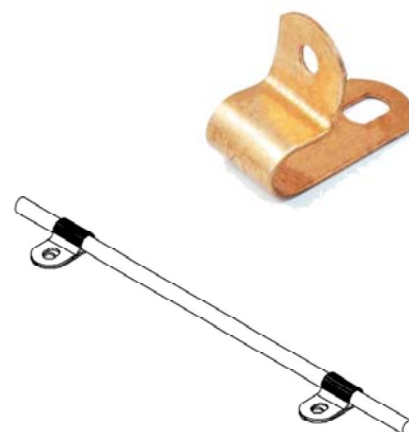

Material: Copper / Aluminium.

TAPE CLIP : FLAT CONDUCTOR

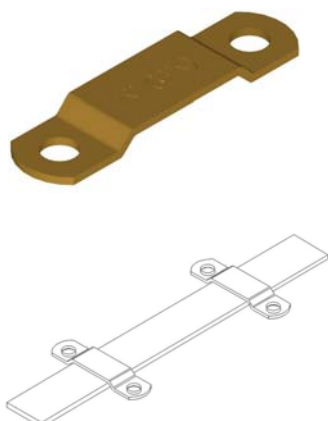

CONDUCTOR SIZE (mm)	CONDUCTOR TYPE	MATERIAL	WEIGHT (Kg)	PART No.
20 x 3	BARE	COPPER	0.02	TPC203
25 x 3	BARE	COPPER	0.02	TPC253
25 x 3	BARE	ALUMINIUM	0.02	TPA203
25 x 3	BARE	ALUMINIUM	0.02	TPA253
25 x 3	PVC	COPPER	0.02	TPC253P

Kingsmill metal tape clips hold the tape flush to the surface and are fixed using two screws.

Material: Copper to BS EN 13601 (formerly BS 1432).

Aluminium to BS EN 755-5.

ADHESIVE CLIP : FLAT CONDUCTOR



CONDUCTOR SIZE (mm)	CONDUCTOR TYPE	PVC COLOUR	WEIGHT (Kg)	PART No.
25 x 3	BARE	BROWN	0.03	PCBN253B/AD
25 x 3	BARE	GREY	0.03	PCGY253B/AD
25 x 3	PVC COVERED	BROWN	0.03	PCBN253P/AD
25 x 3	PVC COVERED	GREY	0.03	PCGY253P/AD
25 x 3	PVC COVERED	BLACK	0.03	PCBL253P/AD
25 x 3	PVC COVERED	STONE	0.03	PCST253P/AD
25 x 3	PVC COVERED	WHITE	0.03	PCWH253P/AD

ADHESIVE CLIP : CIRCULAR CONDUCTOR

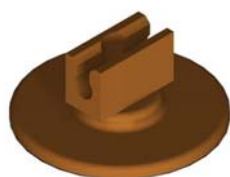

CONDUCTOR DIA. (mm)	CONDUCTOR TYPE	PVC COLOUR	WEIGHT (Kg)	PART No.
8.0	BARE	BROWN	0.02	PCBN08B/AD
8.0	BARE	GREY	0.02	PCGY08B/AD
8.0	PVC COVERED	BROWN	0.02	PCBN08P/AD
8.0	PVC COVERED	GREY	0.02	PCGY08P/AD
8.0	PVC COVERED	BLACK	0.02	PCBL08P/AD
8.0	PVC COVERED	STONE	0.02	PCST08P/AD
8.0	PVC COVERED	WHITE	0.02	PCWH08P/AD

Kingsmill adhesive bases for both flat and circular are used where no mechanical fixing method can be achieved or allowed. The base has a threaded hole and is supplied with a fixing screw to suit our non-metallic DC clip. The base is fixed using the adhesive peel off strip and must be applied to a clean and dust free surface. Please use the Surface Primer to clean the surface. (Part No. SP01).

Material: Polypropylene.

SQUARE CLAMP : FLAT CONDUCTOR

CONDUCTOR SIZE (mm)	CONDUCTOR MATERIAL	WEIGHT (Kg)	PART No.
25 x 3	ALUMINIUM	0.08	SQCA253-KI
25 x 3	COPPER	0.23	SQCC253
25 x 6	COPPER	0.44	SQCC256
31 x 3	COPPER	0.30	SQCC313
40 x 6	COPPER	0.79	SQCC406
50 x 6	COPPER	1.00	SQCC506

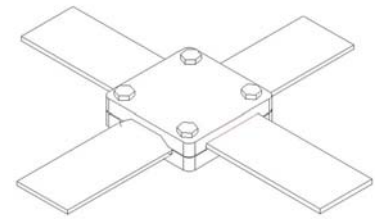
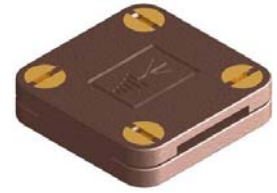

Kingsmill square clamps are designed for a four way connection and are suitable for crossing over tapes, straight through joints or 'T' connections to form a continuous network of tapes.

The base has a countersunk hole in the middle for fixing the clamp in place.

Material: Gunmetal / Aluminium.

Tightening Torque: 6Nm.

 **BS EN 50164-1, Class H**

SQUARE CLAMP : CIRCULAR CONDUCTOR



CONDUCTOR SIZE (mm / mm ²)	CONDUCTOR MATERIAL	WEIGHT (Kg)	PART No.
8 DIA.	ALUMINIUM	0.23	SQCA08
50	COPPER	0.30	SQCW50
70	COPPER	0.26	SQCW70
95	COPPER	0.33	SQCW95
8 DIA	COPPER	0.23	SQCW08

Kingsmill square clamps are designed for a four way connection and are suitable for crossing over cable, straight through joints or 'T' connections to form a continuous network of cables.

The base has a countersunk hole in the middle for fixing the clamp in place.

Material: Gunmetal / Aluminium.

Tightening Torque: 6Nm.

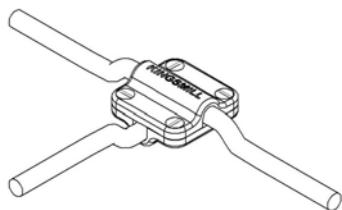

 **BS EN 50164-1, Class H**

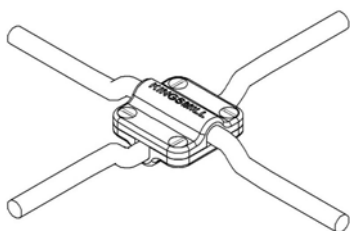

SQUARE CLAMP : FLAT TO CIRCULAR CONDUCTOR

CONDUCTOR SIZE (mm)	CONDUCTOR RANGE (mm / mm ²)	WEIGHT (Kg)	PART No.
25 x 3	8 DIA.	0.16	SQCC25308
25 x 3	50	0.16	SQCC25350
25 x 3	70	0.14	SQCC25370
25 x 3	95	0.12	SQCC25395



Kingsmill square clamps are designed for a four way connection and are suitable for crossing over tapes and cables together in straight through joints or 'T' connections to form a continuous network of tapes and cables.

The base has a countersunk hole in the middle for fixing the clamp in place.

Material: Gunmetal.

Tightening Torque: 6Nm.

 **BS EN 50164-1, Class H**

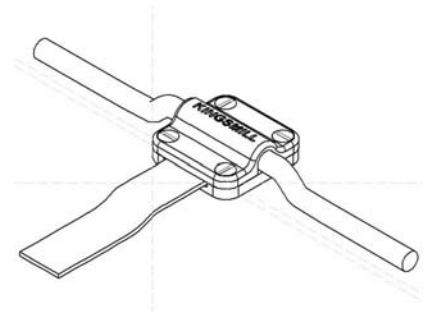

TEE CLAMP

CONDUCTOR DIA. (mm)	CONDUCTOR MATERIAL	WEIGHT (Kg)	PART No.
8.0	COPPER	0.17	TEEC08
8.0	ALUMINIUM	0.07	TEEA08

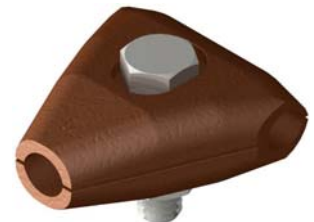

Kingsmill tee clamps are designed for a three way connection.

Material: Gunmetal / Aluminium.

Tightening Torque: 12Nm.

 **BS EN 50164-1, Class H**

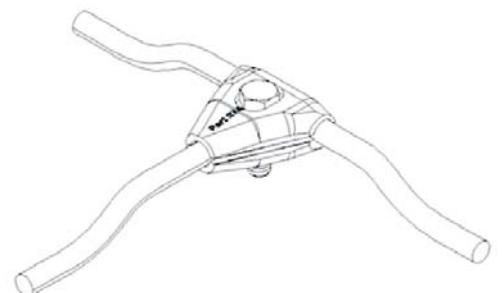

OBLONG TEST CLAMP

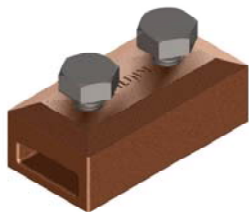

CONDUCTOR SIZE (mm)	CONDUCTOR MATERIAL	WEIGHT (Kg)	PART No.
25 x 3	ALUMINIUM	0.16	OTCA253
25 x 3	COPPER	0.40	OTCC253
31 x 6	COPPER	0.38	OTCC316
40 x 5	COPPER	0.53	OTCC405

Kingsmill oblong test clamps are designed to join conductor tape to facilitate in the annual testing of the lightning protection system. The clamp is designed to allow the conductor to be overlapped and secured using bolts.

Material: Gunmetal / Aluminium.

Tightening Torque: 15Nm.

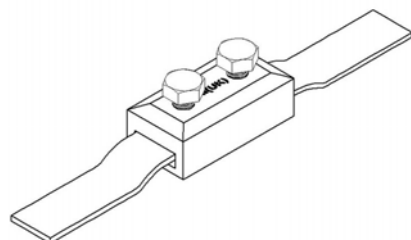

 **BS EN 50164-1, Class H**

PLATE TYPE TEST CLAMP





CONDUCTOR SIZE (mm)	CONDUCTOR MATERIAL	WEIGHT (Kg)	PART No.
25 x 3	COPPER	0.90	PTTC253

Kingsmill plate type test clamps are used to form a disconnecting joint between the down conductor system and the earthing system. The conductors are secured by the top and bottom plates being clamped together.

Material: Gunmetal.

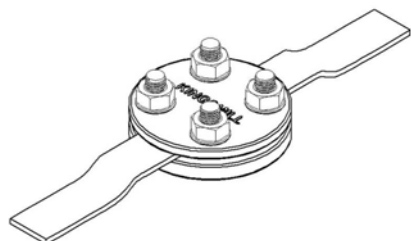
Tightening Torque: 15Nm.



 **BS EN 50164-1, Class H**

SCREW DOWN TEST CLAMP

CONDUCTOR SIZE (mm)	CONDUCTOR MATERIAL	WEIGHT (Kg)	PART No.
25 x 3	COPPER	0.84	SDTC253

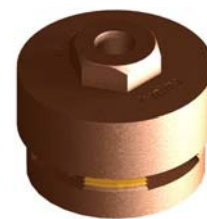

Kingsmill screw down test clamps are designed to join 25 x 3 conductor tape to facilitate in the annual testing of the lightning protection system. The heavy duty lid simply screws on and off the threaded base.

Material: Gunmetal.

Tightening Torque: 20Nm.

 **BS EN 50164-1, Class H**



CABLE TEST CLAMP

CONDUCTOR SIZE (mm)	CONDUCTOR MATERIAL	WEIGHT (Kg)	PART No.
50	COPPER	0.40	TC50
70	COPPER	0.40	TC70
95	COPPER	0.40	TC95



Kingsmill cable test clamps are used to form a disconnecting joint between the down conductor system and the earthing system. The conductors are overlapped end to end and are secured together using two bolts.

Material: Gunmetal.

Tightening Torque: 6Nm.

 **BS EN 50164-1, Class H**

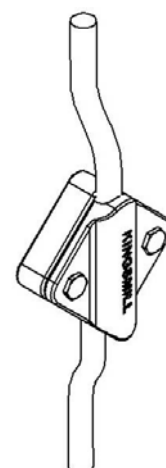

BI-METALLIC CONNECTORS

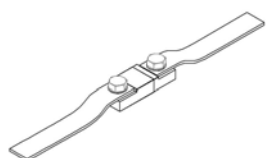
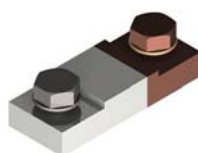
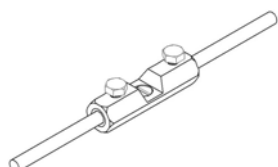
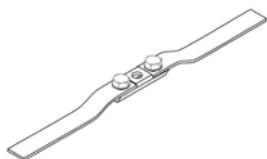

CONDUCTOR SIZE (mm)	MATERIAL	WEIGHT (Kg)	PART No.
25 x 3	STAINLESS STEEL	0.18	BM253HS
8 DIA. OR 50mm ²	STAINLESS STEEL	0.18	BM08HS
25 x 3 TO 8 DIA. OR 50mm ²	STAINLESS STEEL	0.18	BM08253SS
25 x 3	COPPER / ALUMINIUM	0.18	BM253FC

Kingsmill bi-metallic test clamps are designed to connect aluminium conductor to copper earth conductor. They are a practical joining method without the need for tinning, riveting or wrapping around the joint. It is recommended that oxide inhibiting compound (UNP20) is used with the bi-metallic range of test clamps.

Material: Stainless steel grade 316 (BM253HS / BM08HS / BM08253SS.

Copper / Aluminium fuse welded (BM253FC)

Tightening Torque: 12Nm.

TEST CLAMP : FLAT TO CIRCULAR CONDUCTOR



CONDUCTOR DIA. (mm)	CONDUCTOR SIZE (mm)	CONDUCTOR MATERIAL	MATE-	WEIGHT (Kg)	PART No.
8.0	25 x 3	COPPER		0.20	TC08
8.0	25 x 3	ALUMINIUM		0.09	TA08

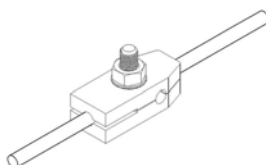
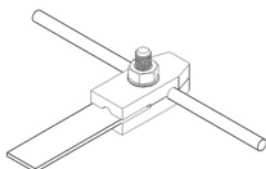
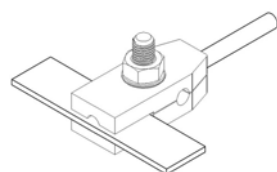

Kingsmill test clamps are used to form a disconnecting joint between either 8mm to 8mm diameter conductor or 8mm to 25 x 3mm conductor.

Material: Gunmetal / Aluminium.

Tightening Torque: 12Nm.

AIR TERMINALS

ROD LENGTH (mm)	ROD DIAMETER (mm)	MATERIAL	WEIGHT (Kg)	PART No.
500	10	COPPER	0.33	ATCR1005
1000	10	COPPER	0.65	ATCR1010
500	16	COPPER	0.75	ATCR1605
1000	16	COPPER	1.50	ATCR1610
1500	16	COPPER	2.25	ATCR1615
2000	16	COPPER	3.00	ATCR1620
2500	16	COPPER	3.75	ATCR1625
3000	16	COPPER	4.50	ATCR1630
500	10	ALUMINIUM	0.11	ATAR1005
1000	10	ALUMINIUM	0.20	ATAR1010
500	16	ALUMINIUM	0.29	ATAR1605
1000	16	ALUMINIUM	0.58	ATAR1610
1500	16	ALUMINIUM	0.87	ATAR1615
2000	16	ALUMINIUM	1.16	ATAR1620
2500	16	ALUMINIUM	1.45	ATAR1625
3000	16	ALUMINIUM	1.74	ATAR1630



Kingsmill air terminals are designed to be used with either the standard air terminal base, multi purpose base or the side mounted brackets.

Material: Copper / Aluminium.

 **BS EN 50164-2**

ELEVATION RODS

ROD LENGTH (mm)	ROD DIAMETER (mm)	WEIGHT (Kg)	PART No.
500	16	0.75	CELV1605
1000	16	1.50	CELV1610
1500	16	2.25	CELV1615
2000	16	3.0	CELV1620
2500	16	3.75	CELV1625
3000	16	4.50	CELV1630



Kingsmill elevation rods are designed to be used with either the standard air terminal base, multi purpose base or the side mounted brackets and the multi point air terminal.

Material: Copper.

 **BS EN 50164-2**

MULTI POINTS

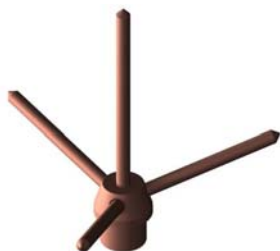

ROD DIA. (mm)	MATERIAL	WEIGHT (Kg)	PART No.
16	COPPER	0.75	MPAT

Kingsmill multi points are designed to be used with the Kingsmill elevation rod.

Material: Copper.

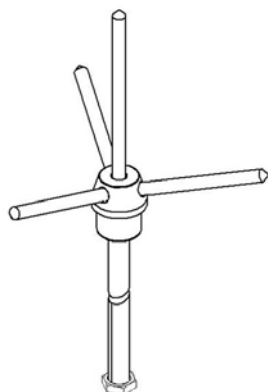

AIR TERMINAL BASES

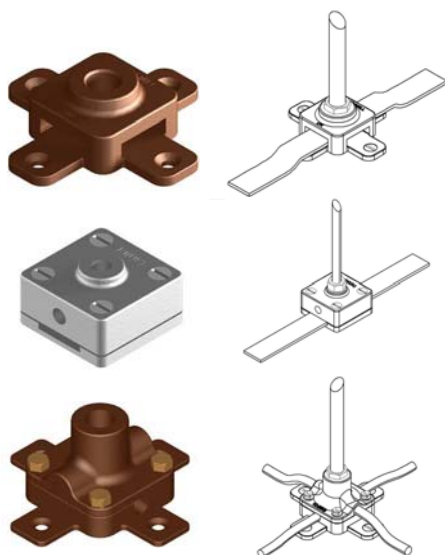

ROD DIA. (mm)	CONDUCTOR SIZE (mm)	MATERIAL	WEIGHT (Kg)	PART No.
16	25	COPPER	0.50	CATB16
16	25	ALUMINIUM	0.17	AATB16
10	8 OR 25 x 3	ALUMINIUM	0.15	AATB10
16	50mm ²	COPPER	0.80	CATB50
16	70mm ²	COPPER	0.75	CATB70
16	95mm ²	COPPER	0.90	CATB95

Kingsmill air terminal bases are designed to be used with the Kingsmill Air terminals and elevation rods.

Material: Gunmetal / Aluminium.

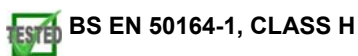

SIDE MOUNTED ROD BRACKETS

ROD DIA. (mm)	MATERIAL	WEIGHT (Kg)	PART No.
16	GUNMETAL	0.91	RBC16
16	ALUMINIUM	0.29	RBA16

Kingsmill side brackets are designed to be installed to the side of the building where it is not possible to fit a conventional air terminal base.

The side mounted brackets are to be used in conjunction with the rod to tape coupling.

Material: Gunmetal / Aluminium.



ROD TO TAPE COUPLING

ROD DIA. (mm)	CONDUCTOR SIZE (mm)	MATERIAL	WEIGHT (Kg)	PART No.
16	25 x 3	GUNMETAL	0.23	RBCC16
16	25 x 3	ALUMINIUM	0.08	RBCA16
16	8	GUNMETAL	0.25	RBCC-08

Kingsmill rod to tape couplers are designed to be used in conjunction with our side mounted brackets.

Material: Gunmetal / Aluminium.



BS EN 50164-1, CLASS H

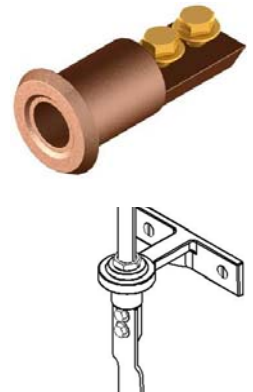

PUDDLE FLANGES

NOMINAL DIM. (mm)	MATERIAL	WEIGHT (Kg)	PART No.
150 x 150 x 625	COPPER	1.54	CPF
150 x 150 x 625	ALUMINIUM	0.50	APF

Kingsmill puddle flanges are designed to take lightning conductors through roofs etc.

Material: Copper to BS EN 13601 / Aluminium to BS EN 755-5.

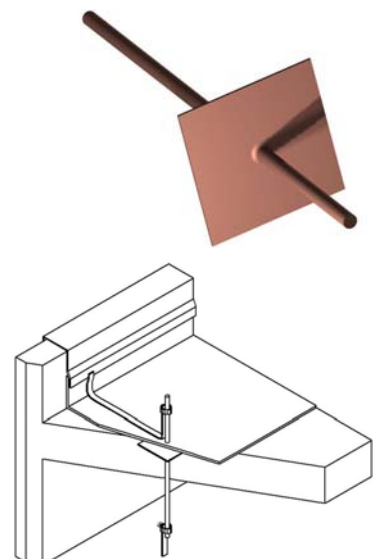

TINNED COPPER CABLE LUG



Kingsmill compression tube lugs are manufactured from high conductive electrolytic copper and are tin plated to provide excellent corrosion resistance.

We can also supply compression tube lugs complete with two stud holes.

Other sizes are available upon request.

CABLE SIZE (mm ²)	STUD SIZE DIA. (X) (mm)	WEIGHT (Kg)	PART No.
16	6.0	0.01	LTC16,06
16	8.0	0.01	LTC16,08
16	10	0.01	LTC16,10
16	12	0.01	LTC16,12
25	6.0	0.01	LTC25,06
25	8.0	0.01	LTC25,08
25	10	0.01	LTC25,10
25	12	0.01	LTC25,12
35	6.0	0.01	LTC35,06
35	8.0	0.01	LTC35,08
35	10	0.01	LTC35,10
35	12	0.01	LTC35,12
50	6.0	0.02	LTC50,06
50	8.0	0.02	LTC50,08
50	10	0.02	LTC50,10
50	12	0.02	LTC50,12
70	8.0	0.04	LTC70,08
70	10	0.04	LTC70,10
70	12	0.04	LTC70,12
70	14	0.04	LTC70,14
70	16	0.04	LTC70,16
95	8.0	0.06	LTC95,08
95	10	0.06	LTC95,10
95	12	0.06	LTC95,12
95	14	0.06	LTC95,14
95	16	0.06	LTC95,16
120	10	0.06	LTC120,10
120	12	0.06	LTC120,12
120	14	0.06	LTC120,14
120	16	0.06	LTC120,16
150	10	0.09	LTC150,10
150	12	0.09	LTC150,12
150	14	0.09	LTC150,14
150	16	0.09	LTC150,16
185	12	0.11	LTC185,12
185	14	0.11	LTC185,14
185	16	0.11	LTC185,16
240	12	0.14	LTC240,12
240	14	0.14	LTC240,14
240	16	0.14	LTC240,16
300	12	0.17	LTC300,12
300	14	0.17	LTC300,14
300	16	0.17	LTC300,16
400	12	0.21	LTC400,12
400	14	0.21	LTC400,14
400	16	0.21	LTC400,16

C CRIMP CONNECTORS

DIMENSIONS (mm)			CAPACITIES (mm ²)						DIES	PART No.		
L	H	B	TOTALS MIN MAX		MIN 1 2		MAX 1 2			ASSEMBLY	COPPER	TIN-PLATED COPPER
9	10	6.4	3	12	1.5	1.5	6	6	A	... HCU 10	C6	C6E
12	12.5	8.5	13	20	10	2x1.5	10	10	A	... HCU 125	C10	C10E
17	19	11.5	19	32	10 16	9 2x1.5	16	16	A + B	... HCU 70	C16	C16E
12	19.8	13	17	35	16	1.5	25	25	A	... HCU 95	C25-10	C25-10E
19	21	11.9	35	41	25	10	25	25	A + B	... HCU 95	C25 pm	C25PME
20	24.3	15	33	56	25 27 30	10 6 2x1.5	29.3 35 30	29.3 35 30	A A + B A + B	... HCU 150	C25	C25E
20	26.5	15	53	70	30 50	25 2x1.5	35 50	35 50	A + B A + B	... HCU 150	C35	C35E
20	26.5	17.2	66	100	50 63	16 2x1.5	50 70 75	50 70 75	A A A	... HCU 150	C50	C50E
28	33	21	54	110	50	4	70	70	A	... HCU 240	C70-35	C70-35E
28	34	21	85	140	50	35	70	70	A	... HCU240	C70	C70E
30	41	26	105	170	75 70 90	30 35 16	95 95	95 95	A + B A + B	... CC 95	C75	C75E
30	41	26	99	140	95	4	100	100	A	... CC 95	C95-35	C95-35E
30	41	26	150	190	75	75	95	95	A	... CC 95	C95	C95E
30	45	28	156	240	120 150	35 6	120 150	120 150	A A	... CC 150	C120	C120E
30	45	28	225	300	150	75	150	150	A + B	... CC 150	C150	C150E
30	45	28	260	300	185	75			A + B	... CC 150	C185-95	C185-95E
35	54	33	210	370	115 150	95 60	185 185	185 185	A + B A + B	... CC 185	C185	C185E
40	54	33.5	387	480	240	147	240	240	A	... CC 185	C240	C240E

Kingsmill 'C' crimp connectors are manufactured from high purity copper profiles and are suitable for a variety of uses, either to create an earthing network or tapping off overhead distribution lines.

Kingsmill 'C' crimps are designed to allow connections to cable to be formed without the need to cut the main cable.

We also provide a range of sizes that can be supplied as either plain or tinned.

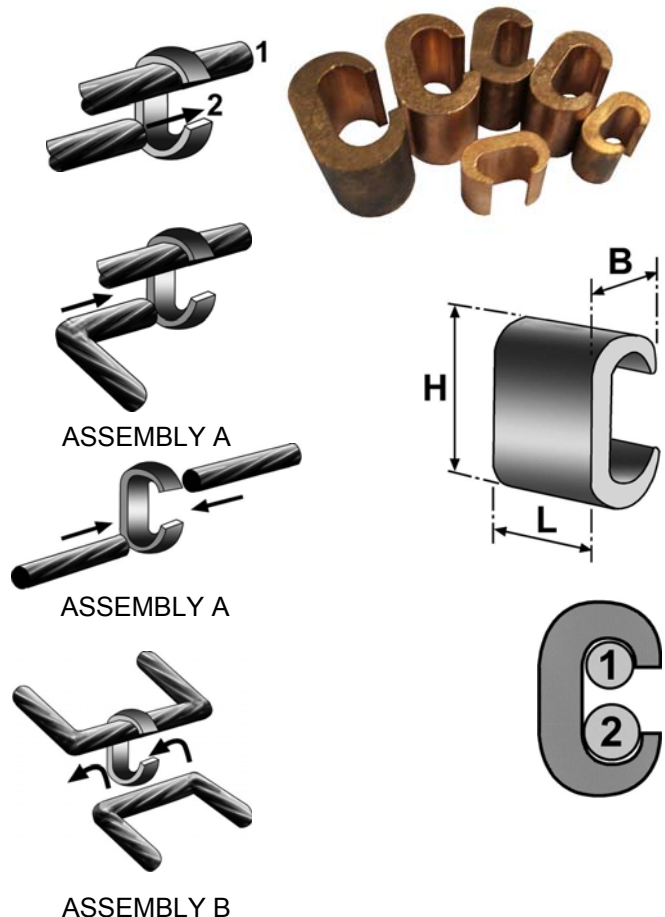

SPLIT BOLT CONNECTORS



MAIN		TAP		WEIGHT (Kg)	PART No.
MIN (mm ²)	MAX (mm ²)	MIN (mm ²)	MAX (mm ²)		
4.0	10	2.5	10	0.02	SBC8
10	16	2.5	16	0.03	SBC4
16	25	4.0	25	0.04	SBC2
25	35	4.0	35	0.06	SBC1
35	50	4.0	50	0.09	SBC10
35	70	4.0	70	0.14	SBC20
50	95	4.0	95	0.17	SBC30
50	120	6.0	120	0.18	SBC40
95	185	6.0	185	0.35	SBC50

Kingsmill split bolt connectors will accept a range of stranded or solid circular conductors. No specialist tools are required for installation.

Material: High strength copper alloy.

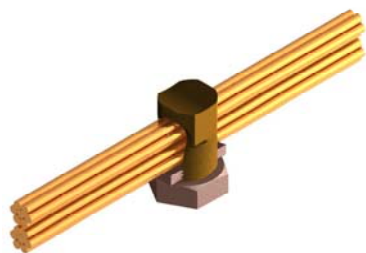

BS 7430

TINMANS SOLDER

MATERIAL	WEIGHT (Kg)	PART No.
60% TIN, 40% LEAD	0.26	TINS1/2



60% Tin, 40% Lead.

1/2LB Stick Tinmans Solder.

300mm length each approximately.

DENSO TAPE

COIL SIZE (mm)	MATERIAL	WEIGHT (Kg)	PART No.
50 x 10000	SYNTHETIC FABRIC	0.76	DEN050



Denso tape offers a weatherproof seal when wrapped around joints to stop the ingress of moisture, preventing corrosion.

Synthetic - impregnated and coated with a neutral petroleum compound.

UNIAL PASTE



SIZE (Kg)	MATERIAL	WEIGHT (Kg)	PART No.
0.25	OXIDE INHIBITING COMPOUND	0.25	UNP250

Recommended for use on aluminium to copper connections, bare conductors or bus bar.

Unial paste assures a high conductivity joint by sealing out air and moisture for the prevention of corrosion and reformation of oxide film.

SILFOS



SIZE (mm) (W x L)	MATERIAL	WEIGHT (Kg)	PART No.
50 x 8000	SEE BELOW	0.425	SF050

Silfos allows copper to be brazed in air without the use of flux.

An alloy of silver, phosphorus and copper content.

AN INTRODUCTION TO KINGSWELD

KingsWeld - Products & General Information:

The exothermic-welding electrical connection process is a simple, efficient method of welding copper to copper or copper to steel. No outside source is required when using this method. KingsWeld welding connections use the high temperature of reaction of powdered copper oxide and aluminium. The reaction takes place in a semi-permanent graphite mould that can last for up to fifty or more welds if properly cared for.

The KingsWeld welding reaction takes place in a few seconds, therefore the total amount of heat (calories or BTUs) applied to the conductors or the surface is considerably less than that employed in brazing or soldering. That is an important consideration when welding to insulated cable or thin wall pipe. KingsWeld welding is ideal for field use, since it is light and portable and requires no outside power source. It requires very little time or skill to obtain an efficient, maintenance-free electrical connection.

THE KINGSWELD WELDING CONNECTION: The KingsWeld connection is a molecular weld, and the weld metal has the same melting point as copper. Because of these factors, along with the increase cross section of the connection, KingsWeld connections:

- 1) Will not be affected by a high current surge. Tests have shown that the electrical conductor will melt before the KingsWeld connection when subjected to high short-circuit current. Consult IEE Standard 80-1989.
- 2) Will Not loosen or corrode at the point of weld. There are no contact surfaces or mechanical pressures involved. A KingsWeld connection becomes an integral part of the conductor.
- 3) Have a high current-carrying capacity equal to or greater than that of the conductor's circuit current.



KingsWeld supports grounding and lightning protection for infrastructure worldwide.



KingsWeld supports cathodic protection and corrosion-control projects worldwide.



KingsWeld supports both the traditional and renewable energy and utility infrastructure worldwide.



KingsWeld supports railway projects for signalling and power worldwide.

AN INTRODUCTION TO KINGSWELD

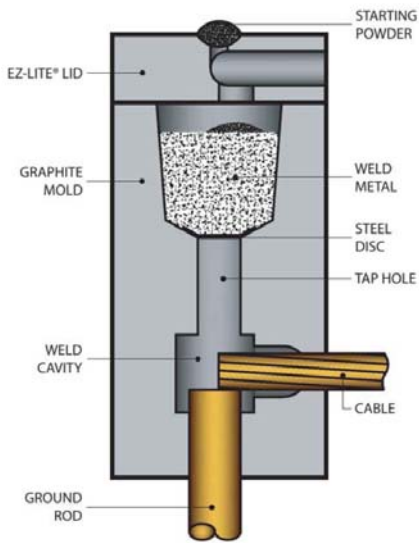

How to Order KingsWeld Material:

In order to receive the correct material, it is important to have all the relevant information regarding the type of installation you are to make before selecting the KingsWeld material. Information required to select the correct materials are:

1. Materials to be welded (Copper, Steel, Cast Iron etc)
2. Cable size and type (Solid or Stranded, Copper or Steel)
3. Weld type (Configuration)

Additional information may be required for a particular weld type. If more information is required, it will be asked for with that weld type at the time of quotation.

After you have selected the cable size and weld type to be used, use the selector chart to find the page number for that particular weld type. After turning to the correct page, find the correct cable size and follow it across to get the Mould number, cartridge size and price key. If required, select sleeves, packing material, ground plates, lugs, etc. Specify handle clamp if required. All moulds with Price Key 4, 7 and 17 require 40-0106-00 handle clamps and all moulds with price key 5, 6 and 8 require 40-0107-00 handle clamps. All other price key moulds come complete with frame. To clean the cable, order the cable cleaning brush 38-0135-00 and to clean steel or cast iron surface use 38-0101-00 rasp. Before making any connection always read the enclosed instruction sheet. This instruction sheet tells you about the precautions to be taken, how to clean the materials to be welded and how to make the weld connection. Basic material required to make a KingsWeld connection: The Correct KingsWeld Mould, KingsWeld Handle Clamps (if required), Weld Metal, Flint Gun, Wire Brush.

The Correct KingsWeld Mould, KingsWeld Handle Clamps (if required), Weld Metal, Flint Gun, Wire Brush.

KingsWeld equipment has been used to weld materials other than copper for electrical purposes.

Materials welded have included: Stainless Steel, Monel, Copper Clad Steel, Steel, Rail Brass, CopperWeld, Plain Steel, Bronze, Chromax, Nichrome, Nichrome V, Everdur, Galvanised Steel, Wrought Iron, Cast Iron, Kama, Cor-Ten, Silicone Bronze, Columbium, Niobium.

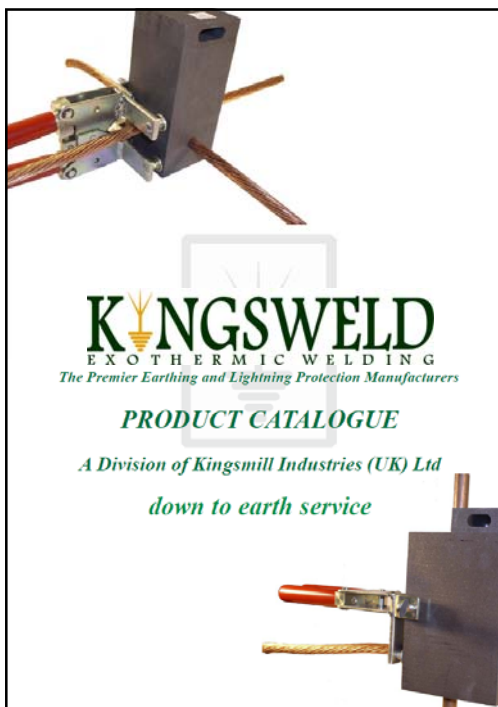

Please refer to our Kingsweld Catalogue for a more extensive range of Mould's and accessories available. Please contact the Sales Office for your copy of the KingsWeld catalogue.

Section I		Section I	
type CS-34		type CS-33	
Horizontal Cable Thru to Horizontal Steel		Horizontal Cable Tap to Horizontal Cast Iron	
Pipe for Cathodic Protection		Pipe for Cathodic Protection	
CABLE SIZE (Sq. mm)	PIPE DIA. (mm)	WELD METAL CAT. NO.	HANDLE CLAMP KEY CAT. NO.
15, 25, 35, 50, 70, 95, 120, 150, 185, 240, 300, 370, 450, 550, 675, 840, 1050, 1300, 1650, 2100, 2700, 3400, 4200, 5100, 6300, 7800, 9600, 12000, 15000, 18000, 22500, 28000, 35000, 43000, 52000, 63000, 78000, 96000, 120000, 150000, 180000, 225000, 280000, 350000, 430000, 520000, 630000, 780000, 960000, 1200000, 1500000, 1800000, 2250000, 2800000, 3500000, 4300000, 5200000, 6300000, 7800000, 9600000, 12000000, 15000000, 18000000, 22500000, 28000000, 35000000, 43000000, 52000000, 63000000, 78000000, 96000000, 120000000, 150000000, 180000000, 225000000, 280000000, 350000000, 430000000, 520000000, 630000000, 780000000, 960000000, 1200000000, 1500000000, 1800000000, 2250000000, 2800000000, 3500000000, 4300000000, 5200000000, 6300000000, 7800000000, 9600000000, 12000000000, 15000000000, 18000000000, 22500000000, 28000000000, 35000000000, 43000000000, 52000000000, 63000000000, 78000000000, 96000000000, 120000000000, 150000000000, 180000000000, 225000000000, 280000000000, 350000000000, 430000000000, 520000000000, 630000000000, 780000000000, 960000000000, 1200000000000, 1500000000000, 1800000000000, 2250000000000, 2800000000000, 3500000000000, 4300000000000, 5200000000000, 6300000000000, 7800000000000, 9600000000000, 12000000000000, 15000000000000, 18000000000000, 22500000000000, 28000000000000, 35000000000000, 43000000000000, 52000000000000, 63000000000000, 78000000000000, 96000000000000, 120000000000000, 150000000000000, 180000000000000, 225000000000000, 280000000000000, 350000000000000, 430000000000000, 520000000000000, 630000000000000, 780000000000000, 960000000000000, 1200000000000000, 1500000000000000, 1800000000000000, 2250000000000000, 2800000000000000, 3500000000000000, 4300000000000000, 5200000000000000, 6300000000000000, 7800000000000000, 9600000000000000, 12000000000000000, 15000000000000000, 18000000000000000, 22500000000000000, 28000000000000000, 35000000000000000, 43000000000000000, 52000000000000000, 63000000000000000, 78000000000000000, 96000000000000000, 120000000000000000, 150000000000000000, 180000000000000000, 225000000000000000, 280000000000000000, 350000000000000000, 430000000000000000, 520000000000000000, 630000000000000000, 780000000000000000, 960000000000000000, 1200000000000000000, 1500000000000000000, 1800000000000000000, 2250000000000000000, 2800000000000000000, 3500000000000000000, 4300000000000000000, 5200000000000000000, 6300000000000000000, 7800000000000000000, 9600000000000000000, 12000000000000000000, 15000000000000000000, 18000000000000000000, 22500000000000000000, 28000000000000000000, 35000000000000000000, 43000000000000000000, 52000000000000000000, 63000000000000000000, 78000000000000000000, 96000000000000000000, 120000000000000000000, 150000000000000000000, 180000000000000000000, 225000000000000000000, 280000000000000000000, 350000000000000000000, 430000000000000000000, 520000000000000000000, 630000000000000000000, 780000000000000000000, 960000000000000000000, 1200000000000000000000, 1500000000000000000000, 1800000000000000000000, 2250000000000000000000, 2800000000000000000000, 3500000000000000000000, 4300000000000000000000, 5200000000000000000000, 6300000000000000000000, 7800000000000000000000, 9600000000000000000000, 12000000000000000000000, 15000000000000000000000, 18000000000000000000000, 22500000000000000000000, 28000000000000000000000, 35000000000000000000000, 43000000000000000000000, 52000000000000000000000, 63000000000000000000000, 78000000000000000000000, 96000000000000000000000, 120000000000000000000000, 150000000000000000000000, 180000000000000000000000, 225000000000000000000000, 280000000000000000000000, 350000000000000000000000, 430000000000000000000000, 520000000000000000000000, 630000000000000000000000, 780000000000000000000000, 960000000000000000000000, 1200000000000000000000000, 1500000000000000000000000, 1800000000000000000000000, 2250000000000000000000000, 2800000000000000000000000, 3500000000000000000000000, 4300000000000000000000000, 5200000000000000000000000, 6300000000000000000000000, 7800000000000000000000000, 9600000000000000000000000, 12000000000000000000000000, 15000000000000000000000000, 18000000000000000000000000, 22500000000000000000000000, 28000000000000000000000000, 35000000000000000000000000, 43000000000000000000000000, 52000000000000000000000000, 63000000000000000000000000, 78000000000000000000000000, 96000000000000000000000000, 120000000000000000000000000, 150000000000000000000000000, 180000000000000000000000000, 225000000000000000000000000, 280000000000000000000000000, 350000000000000000000000000, 430000000000000000000000000, 520000000000000000000000000, 630000000000000000000000000, 780000000000000000000000000, 960000000000000000000000000, 1200000000000000000000000000, 1500000000000000000000000000, 1800000000000000000000000000, 2250000000000000000000000000, 2800000000000000000000000000, 3500000000000000000000000000, 4300000000000000000000000000, 5200000000000000000000000000, 6300000000000000000000000000, 7800000000000000000000000000, 9600000000000000000000000000, 12000000000000000000000000000, 15000000000000000000000000000, 18000000000000000000000000000, 22500000000000000000000000000, 28000000000000000000000000000, 35000000000000000000000000000, 43000000000000000000000000000, 52000000000000000000000000000, 63000000000000000000000000000, 78000000000000000000000000000, 96000000000000000000000000000, 120000000000000000000000000000, 150000000000000000000000000000, 180000000000000000000000000000, 225000000000000000000000000000, 280000000000000000000000000000, 350000000000000000000000000000, 430000000000000000000000000000, 520000000000000000000000000000, 630000000000000000000000000000, 780000000000000000000000000000, 960000000000000000000000000000, 1200000000000000000000000000000, 1500000000000000000000000000000, 1800000000000000000000000000000, 2250000000000000000000000000000, 2800000000000000000000000000000, 3500000000000000000000000000000, 4300000000000000000000000000000, 5200000000000000000000000000000, 6300000000000000000000000000000, 7800000000000000000000000000000, 9600000000000000000000000000000, 12000000000000000000000000000000, 15000000000000000000000000000000, 18000000000000000000000000000000, 22500000000000000000000000000000, 28000000000000000000000000000000, 35000000000000000000000000000000, 43000000000000000000000000000000, 52000000000000000000000000000000, 63000000000000000000000000000000, 78000000000000000000000000000000, 96000000000000000000000000000000, 120000000000000000000000000000000, 150000000000000000000000000000000, 180000000000000000000000000000000, 225000000000000000000000000000000, 280000000000000000000000000000000, 350000000000000000000000000000000, 430000000000000000000000000000000, 520000000000000000000000000000000, 630000000000000000000000000000000, 780000000000000000000000000000000, 960000000000000000000000000000000, 1200000000000000000000000000000000, 1500000000000000000000000000000000, 1800000000000000000000000000000000, 2250000000000000000000000000000000, 2800000000000000000000000000000000, 3500000000000000000000000000000000, 4300000000000000000000000000000000, 5200000000000000000000000000000000, 6300000000000000000000000000000000, 7800000000000000000000000000000000, 9600000000000000000000000000000000, 12000000000000000000000000000000000, 15000000000000000000000000000000000, 18000000000000000000000000000000000, 22500000000000000000000000000000000, 28000000000000000000000000000000000, 35000000000000000000000000000000000, 43000000000000000000000000000000000, 52000000000000000000000000000000000, 63000000000000000000000000000000000, 78000000000000000000000000000000000, 96000000000000000000000000000000000, 120000000000000000000000000000000000, 150000000000000000000000000000000000, 180000000000000000000000000000000000, 225000000000000000000000000000000000, 280000000000000000000000000000000000, 350000000000000000000000000000000000, 430000000000000000000000000000000000, 520000000000000000000000000000000000, 630000000000000000000000000000000000, 780000000000000000000000000000000000, 960000000000000000000000000000000000, 1200000000000000000000000000000000000, 1500000000000000000000000000000000000, 1800000000000000000000000000000000000, 2250000000000000000000000000000000000, 2800000000000000000000000000000000000, 3500000000000000000000000000000000000, 4300000000000000000000000000000000000, 5200000000000000000000000000000000000, 6300000000000000000000000000000000000, 7800000000000000000000000000000000000, 9600000000000000000000000000000000000, 12000000000000000000000000000000000000, 15000000000000000000000000000000000000, 18000000000000000000000000000000000000, 22500000000000000000000000000000000000, 28000000000000000000000000000000000000, 35000000000000000000000000000000000000, 43000000000000000000000000000000000000, 52000000000000000000000000000000000000, 63000000000000000000000000000000000000, 78000000000000000000000000000000000000, 96000000000000000000000000000000000000, 120000000000000000000000000000000000000, 150000000000000000000000000000000000000, 180000000000000000000000000000000000000, 225000000000000000000000000000000000000, 280000000000000000000000000000000000000, 350000000000000000000000000000000000000, 430000000000000000000000000000000000000, 520000000000000000000000000000000000000, 630000000000000000000000000000000000000, 780000000000000000000000000000000000000, 960000000000000000000000000000000000000, 1200000000000000000000000000000000000000, 1500000000000000000000000000000000000000, 1800000000000000000000000000000000000000, 2250000000000000000000000000000000000000, 2800000000000000000000000000000000000000, 3500000000000000000000000000000000000000, 4300000000000000000000000000000000000000, 5200000000000000000000000000000000000000, 6300000000000000000000000000000000000000, 7800000000000000000000000000000000000000, 9600000000000000000000000000000000000000, 12000000000000000000000000000000000000000, 15000000000000000000000000000000000000000, 18000000000000000000000000000000000000000, 22500000000000000000000000000000000000000, 28000000000000000000000000000000000000000, 35000000000000000000000000000000000000000, 43000000000000000000000000000000000000000, 52000000000000000000000000000000000000000, 63000000000000000000000000000000000000000, 78000000000000000000000000000000000000000, 96000000000000000000000000000000000000000, 1200, 1500, 1800, 225000000000000000000000000000000000000000, 2800, 3500, 4300, 5200, 6300, 7800, 9600, 12000, 15000000			

AN INTRODUCTION TO SURGE PROTECTION

An Introduction to Surge Protection:

Lightning / Surge protection for electrical and electronic systems to the new British and European standard BS EN 62305-4.

Kingsmill Industries (UK) Ltd can offer a complete solution to protect vital electrical and electronic systems from damage. Recently introduced standards put equal importance to protecting the electrical installation and electrical equipment as to the building itself.

Modern micro electronic components are very sensitive to overvoltage's and because many systems are networked, they rely on each other for the system to operate. If one part of the system gets damaged due to lightning or surges the whole system will not operate. The consequential losses suffered during such events i.e. downtime and lost production can be very high.

Kingsmill Industries (UK) Ltd can offer a wealth of experience in helping you decide which product best suits your needs together with our manufacturer who has many years experience in the industry. You can speak to a product specialist who will quickly answer any questions you may have and recommend the correct product for your application. Our catalogue contains the most commonly used products. We have however, over 4000 devices and components, a product for every application.

New Standard BSEN62305-4 1st Sept 2008 & 17th Edition Wiring Regs Amendments 1st Jan 2012.

This new standard replaced BS6651 on the above date, it is now mandatory to fit a lightning current arrester on main incoming panels which are situated in buildings with external lightning conductors or fed by an overhead line. This type of arrester are designated as a Type1, we recommend a combined T1+T2+T3 arrester as this gives additional surge protection for no added cost. The minimum discharge capability for a T1 arrester has to be 50Ka 10/350µs level 3 or 4.

For a Level 1 installation the minimum requirement is 100Ka 10/350µs.

Panels feeding external circuits such as car park lighting, cctv etc should also have a combined T1+T2+T3 arrester fitted as standard.

An example of a T1+T2+T3 combined arrester is SPC25 DS/4+0/LED 10651LED Level 1, 100Ka 10/350µs.

For panels in buildings without external lightning conductors and fed by underground cables a T2 surge arrester is sufficient. Sub-distribution boards or local control panels more than 10 metres from the main in-comer and not feeding external circuits then a Type2 surge arrester can be used.

An example of a T2 surge arrester is Part no SY2-C40X.

Final sub-circuits and sensitive electronic equipment for example fire/burglar panels, PLC's which are fitted more than 10 metres from the last surge arrester should have a T3 surge arrester fitted at the panel or equipment to be protected.

An example of a T3 surge arrester is SY2-D/LED.

For further information including surge protection design and recommendations please contact our sales office.

Three SPD Classes:

Main Incoming Position**CLASS I**

PROTECTION AGAINST
DIRECT LIGHTNING
CURRENTS (LIGHTNING
CURRENT ARRESTER)
(10/350 µs)

Sub Dist. Board Position**CLASS II**

PROTECTION AGAINST
INDIRECT LIGHTNING
EFFECTS (SURGE
ARRESTER)
(10/350 µs)

**Socket Outlet or Final Sub
Circuit****CLASS III**

PROTECTION AGAINST
SWITCHING
OVERVOLTAGES (SURGE
ARRESTER)
(10/350 µs)

PROTECTION FOR INDUSTRIAL / COMMERCIAL / ELECTRICAL

Product sensitive electronic equipment with high quality European manufactured Surge Arresters. Today's highly sensitive electronics require protection, you can achieve this by using the following lightning / surge arresters. They are quick and easy to install, and are competitively priced against other brands.

SPD240



Type 2 single phase and neutral Surge arrester for 230v applications. This unit is ideal for controlling voltage surges and remote lightning strikes. Maximum discharge current 80ka 8/20 μ s. IP56 weatherproof polycarbonate enclosure also available as displayed.

Dimensions:

150 (H) x 115 (D) x 80 (W) (mm)

Backup size of MCB 32A to 63A

Cable Size - 4mm² to 10mm²

SPD415



Type 2 three phase and neutral Surge arrester for 415v applications. This unit is ideal for controlling voltage surges and remote lightning strikes. Maximum discharge current 160ka 8/20 μ s. IP56 weatherproof polycarbonate enclosure also available as displayed.

Dimensions:

150 (H) x 115 (D) x 80 (W) (mm)

Backup size of MCB 32A to 63A

Cable Size - 4mm² to 10mm²

1st AMENDMENT, 17th EDITION WIRING REGS COMPLIANT

PROTECTION FOR INDUSTRIAL / COMMERCIAL / ELECTRICAL

Product sensitive electronic equipment with high quality European manufactured Surge Arresters. Today's highly sensitive electronics require protection, you can achieve this by using the following lightning / surge arresters. They are quick and easy to install, and are competitively priced against other brands.

LSPD240

Combined type 1 & 2 single phase and neutral, direct lightning and surge arrester for 230v applications. This unit is ideal for controlling voltage surges and even direct lightning strikes which directly hit the building. It is mandatory to fit such a device if the building has an external lightning conductor or Faraday Cage.

IP56 weatherproof polycarbonate enclosure also available as displayed.

Dimensions:

225 (H) x 115 (D) x 160 (W) (mm)

Backup size of MCB or fuse 60A min.

Cable Size - 16mm² to 25mm²



LSPD415

Combined type 1 & 2 three phase and neutral, direct lightning and surge arrester for 230v applications. This unit is ideal for controlling voltage surges and even direct lightning strikes which directly hit the building. It is mandatory to fit such a device if the building has an external lightning conductor or Faraday Cage.

IP56 weatherproof polycarbonate enclosure also available as displayed.

Dimensions:

225 (H) x 115 (D) x 160 (W) (mm)

Backup size of MCB or fuse 60A min.

Cable Size - 16mm² to 25mm²



1st AMENDMENT, 17th EDITION WIRING REGS COMPLIANT

PROTECTION FOR INDUSTRIAL / COMMERCIAL / ELECTRICAL

TYPE 2 UNIVERSAL PLUGGABLE SURGE ARRESTERS



SPD According to	IEC61643-1 EN61643-11 Type 2
Maximum continuous operating voltage UcV	(350V DC) 275 VAC
Voltage protection level in Up Voltage protection level at 5kA Up Voltage protection level at 3kA Up	≤1.5kV ≤0.9kV ≤0.6kV
Nominal discharge current In (8/20µs)kA	20kA
Maximum discharge current I _{max} (8/20µs)kA	40kA
Withstand Short Circuit	50kA RMS
Response time ns	<25ns
Dimensions	72(W) 90(H) 66(D)mm, Din-Rail Mountable
Enclosure Material	Yellow/Grey, UL94 V-O
Degree of Protection	IP20
Recommended backup MCB/fuse	32A to 63A
Terminal Capacity: Phase Line Neutral Earth Line Signal Line	2.5-35mm ² 4.0-35mm ² 1.0mm ²
Visual indication of Status	Green - OK, Red - Replace module
Remote Alarm Contact	Contact close if any part of the device fails

ENCLOSURES AVAILABLE UPON
REQUEST

TYPE 2/3 UNIVERSAL PLUGGABLE SURGE ARRESTER - 2 POLE (SP + N)



SY2-D

SY2-D-LED

SPD According to	IEC61643-1 EN61643-11 Type 3
Maximum continuous operating voltage UcV	(275 V)
Voltage protection level at 3kA (8/20µs)	≤0.6kV
Nominal discharge current In (8/20µs)kA	5kA
Maximum discharge current I _{max} (8/20µs)kA	10kA
Response time ns	<25ns
Dimensions	18(W) 90(H) 66(D)mm
Enclosure Material	Grey, UL94 V-O
Degree of Protection	IP20
Recommended backup MCB/fuse	32A or less
Terminal Capacity	1.5mm ² - 4mm ²
Visual indication of Status	Black - OK, Red - Replace module
Remote Alarm Contact	Contact close if any part of the device fails
Din Rail Mountable	Yes

ENCLOSURES AVAILABLE UPON
REQUEST

1st AMENDMENT, 17th EDITION WIRING REGS COMPLIANT

COMPACT T1+T2+T3 COMBINED LIGHTNING CURRENT & SURGE ARRESTER

10020

Maximum continuous operating voltage	Uc	275 AC
Lightning impulse current (10/350)	1 _{mp}	12.5kA
Charge	Q	6.25 As
Specific Energy	W/R	39 kJ/
Maximum discharge current (8/20)	1 _{max}	100kA
Nominal discharge current (8/20)	1 _n	20 kA
Temporary overvoltage (TOV)	U _T	335 V/5 sec
Voltage protection level at 1 _{mp}	U _P	<1.2 kV
Response Time	t _a	< 25 ns
Rec. back-up fuse or MCB		63 AMPS
Lifetime		Min. 100,000 h
Short-circuit withstand capability At max. back-up fuse	I _p	60 kA rms
Weight	m	140g
Let through voltage at 3ka 8/20 μs Short circuit to BS6651:1999		A _{pp} C = 600 V
Part Number 1 Pole		10020
Part Number 4 Pole		10020/4

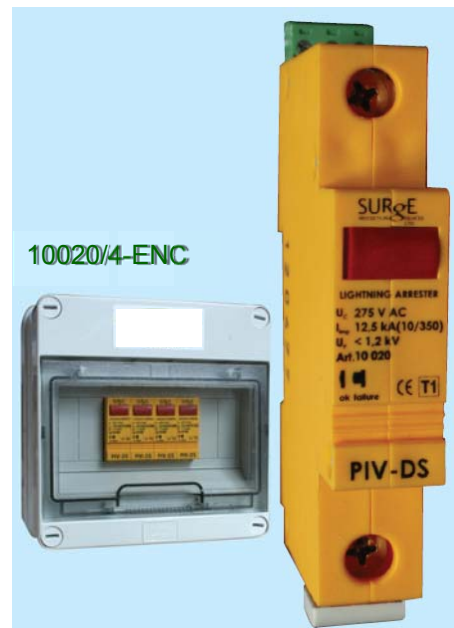

TYPE 1	TYPE 2	TYPE 3
CLASS I	CLASS II	CLASS III



10020/4

CONNECTION OF POTENTIAL - FREE REMOTE MONITORING

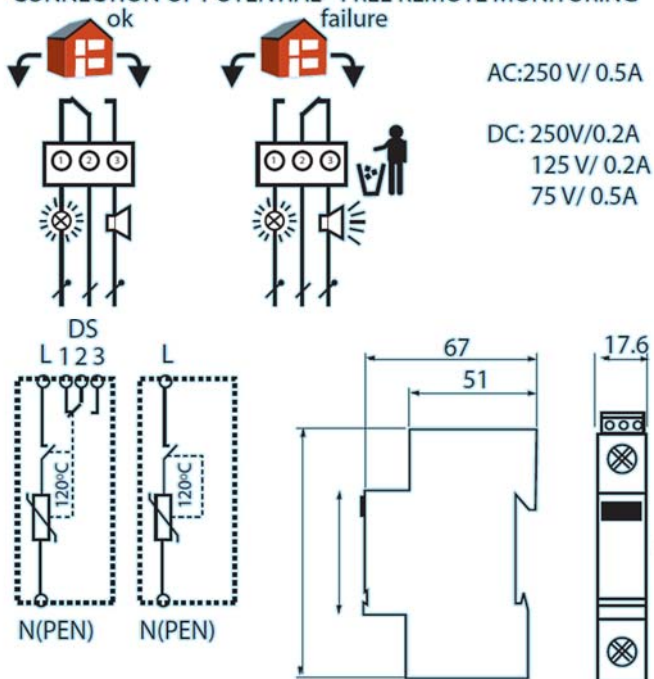

1st AMENDMENT, 17th EDITION WIRING REGS COMPLIANT

TYPE 1+2+3 COMBINED LIGHTNING & SURGE ARRESTERS

4 POLE ARRESTER



10651/LED

ENCLOSURES AVAILABLE UPON
REQUEST

Type SPC25 DS/4+0/LED		
Max continuous operating voltage	Uc	275 V AC
Lightning impulse current (10/350) Charge Specific Energy	Limp Q W/R	25kA 12.5 As 156 kJ/
Total Lightning current (10/350) L1+L2+L3+N-PE	Itotal	100kA
Max. discharge current (8/20) per mode	Imax	120kA
Nominal discharge current (8/20 per mode.	In	50kA
Voltage protection level at iimp	up	<1.2kV
Response Time	tA	<25ns
Temporary overvoltage (TOV)	UT	335 V/5 sec.
Rec.Back-Up fuse/MCCB		63A/100A
Max. Back-Up fuse ("V" connection)		63AgL/gG
Short circuit withstand capability at max back-up fuse	Ip	80kArms
Weight	m	1125g
Lifetime		Min 100,000 h
Let through voltage (I) 3ka 8/20µs, short circuit current to BS 6651+1999 AppC		600V

2 POLE ARRESTER



10650/LED

ENCLOSURES AVAILABLE UPON
REQUEST

Type SPC25 DS/4+0/LED		
Max continuous operating voltage	Uc	275 V AC
Lightning impulse current (10/350) Charge Specific Energy	Limp Q W/R	25kA 12.5 As 156 kJ/
Total Lightning current (10/350) L1+L2+L3+N-PE	Itotal	50kA
Max. discharge current (8/20) per mode	Imax	120kA
Nominal discharge current (8/20 per mode.	In	50kA
Voltage protection level at iimp	up	<1.2kV
Response Time	tA	<25ns
Temporary overvoltage (TOV)	UT	335 V/5 sec.
Rec.Back-Up fuse/MCCB		63A/100A
Max. Back-Up fuse ("V" connection)		63AgL/gG
Short circuit withstand capability at max back-up fuse	Ip	80kArms
Weight	m	565g
Lifetime		Min 100,000 h
Let through voltage (I) 3ka 8/20µs, short circuit current to BS 6651+1999 AppC		600V

1st AMENDMENT, 17th EDITION WIRING REGS COMPLIANT

TELEPHONE / FAX / MODEM SURGE ARRESTER

FOR BT TYPE SOCKETS : TEST CATEGORY D+C+B TO BS EN 61643-21

Number of Protect Pairs	2	DTB2/ART
Nominal Voltage	UN	170v
Max. continuous operating voltage	UC	204v
Nominal current	IN	100mA
C2 Max. discharge current (8/20)	1MAX	2kA
Nominal discharge current (8/20)	IN	1kA
Voltage protection level at 1kV/ μ s	UP	520v
Response time	TA	<30ns
Data rate		10MBit/s
Series impedance per line		1,5 - 10 Ω
Parasitic capacitance	C	1, 5nF
Operating temperature range	U	-40°C ÷ + 80°C
Category tested acc. To IEC 61643:21-		A2, B2, C2, C3, D1



DTB2/ART

10 PAIR TELEPHONE SURGE ARRESTER : D+C+B TO BS EN 61643-21

Nominal direct voltage (UN)	110v=
Max. continuous operating direct voltage (Uc)	180v=
Max. continuous operating alternating voltage (Uc)	180~
Residual voltage at 1kV/ μ s (Ures)	<250V
Nominal operating current at 25°C (IL)	145mA
C2 nominal discharge current (8/20 μ s) (IN)	5kA
Max. impulse discharge current (8/20 μ s) (Imax)	10kA
Protection level at In (Up)	220V
Response time (tA)	<1ns
Thermal response time at 230V/23 A ac and ambient temp. 25°C (TA)	<2s
Capacitance wire-earth (C)	<0.1nF
Series inductance at 25°C (L)	47 μ H
Series resistance per line at 25°C \otimes	3-6 Ω
Max. transmission frequency (fg)	\leq 1.2MHz
Operating temperature range (TU)	-40 to + 80°C
Enclosure material / colour	Thermoplastic, grey or yellow
Dimensions (L x W x H)	110 x 2.25 x 40mm
Net weight / pc	90g

DP10-LSA180

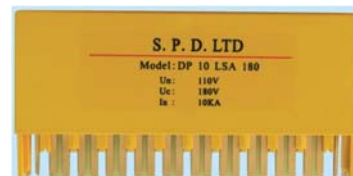

EARTH-BAR



DP1-LSA180



**1st AMENDMENT, 17th EDITION WIRING REGS
COMPLIANT**

DATA SIGNAL LINE ARRESTERS

SP - 30 : SP - 48



Model Number	DATA SIGNAL ARRESTER 2 POLE							
	SP5	SP12	SP15	SP24	SP30	SP48	SP60	SP110
Nominal Voltage: Un	5V-	12V-	15V-	24V-	30V-	48V-	60V-	110V-
Max. Continuous Voltage :DC.Uc	6V-	14.5V-	17.8V-	26.8V-	34.8V-	55.1V-	65V-	170V-
Max. Continuous voltage: Ac.Uc	4.2V	10.2V	12.5V	18.9V	24.5V	38.9V	50V	130V
Nominal Current: In	1A							
C2 Total Nominal Discharge Current In (8/20µs) 20kA								
D1 Total Lightning Impulse Current (10/350µs) imp 10kA								
Voltage protective Core/Core	≤50V	≤70V	≤85v	≤100V	≤130V	≤200V	≤240V	≤730V
Level Upin Core/PE	≤45V	≤60V	≤70v	≤80V	≤80V	≤120V	≤150V	≤400V
Voltage protective CoreCore	≤16V	≤38V	≤50v	≤70V	≤95V	≤150V	≤180V	≤520V
Level: Up 1kv/µs Core/PE	≤8V	≤19V	≤25v	≤35V	≤50V	≤75V	≤95V	≤260V
Response Time: tA	≤1ns							
Resistance	1Ω	1.5Ω	1.6Ω	1.8Ω	1.8Ω	1.8Ω	1.8Ω	≤25ns
Insertion Loss	≤0.3dB							
Working Frequency	≤10MHz							
Degree of Protection	IP20							
Dimensions	150 (H) x 115 (D) x 80 (W) (mm)							
Enclosure Material	Polyamide PA6.6							
Connector	Screw Terminals							
Signal SPD - REP-SP series								

CO-AXIAL BNC C.C.T.V. ARRESTER



Model Number.	D-24/BNC
Nominal Voltage (V) Un	24
Maximum Continuous Voltage (V) Uc	24/28
C2 Nominal Discharge Current (8/20µs) per line In	5kA
C2 Nominal Discharge Current (8/20µs) shield-PG In	10kA
Voltage Protection level Line-Shield	≤300
Voltage Protection level Line-Shield	≤50
Transmission Speed (bps) Vs	10Mbps
Series impedance per line (Ohm)	3 Ohm
Insertion loss (dB)	0.5 @ 10MHz
Response time Ta	1ns
Type of Connection IN/OUT	BNC Female / Male
Dimensions (mm)	70 (H) x 25 (D) x 70
Environment Temperature (°C)	-25 ~ + 70

Surge arresters for coaxial Ethernet network systems protect against surges at the boundaries from lightning protection zone 0 3. Data network protector in accordance with IEC614321. Limit the transients with gas discharge tubes and transzorb diodes.

Two-stage protection circuit in aluminium housing. BNC connector for Ethernet systems. Simple installation. This can also be applied for the protection of video signals, cameras and / or TV systems.

1st AMENDMENT, 17th EDITION WIRING REGS COMPLIANT

PROTECTION OF PHOTOVOLTAIC / SOLAR SYSTEMS

SPD-PV1000

Maximum continuous operating voltage UcV	1060v DC
Voltage protection level In Up	4kv
Nominal discharge current In (8/20µs) kA	20kA
Maximum discharge current Imax (8/20µs) kA	40kA
Withstand	50kA RMS
Response time ns	< 25ns
Dimensions	W 4mm H 90mm D 66mm Din-rail mountable
Enclosure material	Grey UL94 V-O
Degree of protection	IP20
Recommend backup MCB/fuse	32A to 63A
Terminal Capacity	Phase line neutral line Earth line Signal line
	2.5~35mm ² 4.0~35mm ² 4.0~35mm ²
Visual indication of status	Green OK, Red, replace module
Din rail mountable	Yes

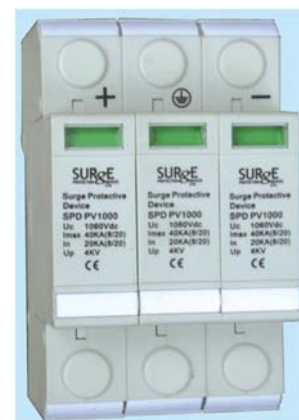

Type 2 to EN61643-11, fault indication, remote signal contact optional, pluggable and replacement modules.

ENCLOSURES AVAILABLE UPON
REQUEST

SPD-PV600

Maximum continuous operating voltage UcV	640v DC
Voltage protection level In Up	2.2kv
Nominal discharge current In (8/20µs) kA	20kA
Maximum discharge current Imax (8/20µs) kA	40kA
Response time ns	< 25ns
Dimensions	W 4mm H 90mm D 66mm Din-rail mountable
Enclosure material	Grey UL94 V-O
Degree of protection	IP20
Recommend backup MCB/fuse	32A to 63A
Terminal Capacity	Phase line neutral line Earth line Signal line
	2.5~35mm ² 4.0~35mm ² 1.0mm ²
Visual indication of status	Green OK, Red, replace module
Din rail mountable	Yes



Type 2 to EN61643-11, fault indication, remote signal contact optional, pluggable and replacement modules.

ENCLOSURES AVAILABLE UPON
REQUEST

1st AMENDMENT, 17th EDITION WIRING REGS
COMPLIANT

STATIC CONTROL : AN INTRODUCTION

The speed and scale of modern manufacturing processes, coupled with changes to the nature and properties of many materials, have increased the range and number of applications where electrostatic charge can accumulate.

Indeed, if your organisation stores, handles or processes flammable liquids, powders, gases and vapours, there is every likelihood that you are exposed to the risk of ignitions caused by static electricity within potentially explosive atmospheres.

It is accepted that each day throughout Europe, a static related incident causes a serious fire or explosion, whilst in the UK alone, HSS statistics suggest that some 50 such incidents occur each year. Apart from business interruption costs resulting from lost production, these incidents may cause serious injury to people and damage to plant and the environment, as well as the possibility of legal action and the attendant bad publicity for the organisation concerned.

In order to combat the build up and unwanted discharge of electrostatic, plant and equipment (both fixed and mobile) is generally bonded and grounded (connected to a high integrity earth), thus dissipating any charge before a dangerous level can be reached.

However this seemingly simple precaution is made complicated when one considers the scale and range of 'safety critical' applications commonly found within the processing industries and also the need to provide practical and 'user friendly' operating procedures.

APPLICATIONS:



GROUNDING DRUMS & CONTAINERS



GROUNDING ROAD TANKERS



GROUNDING PROCESS MACHINERY

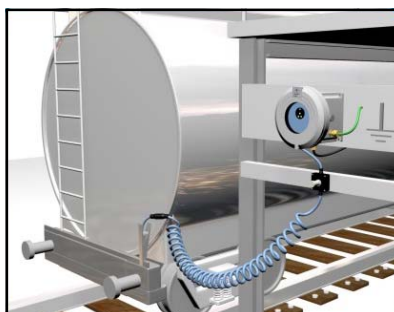

GROUNDING RAIL CARS



GROUNDING PERSONNEL

STAINLESS STEEL H/D CLAMP

STRENGTH	WEIGHT (Kg)	PART No.
HEAVY DUTY	0.40	VESX90



Twin Tungsten carbide teeth to provide a very reliable earth connection.

Designed for drums, vessels & IBC's for example.

Powerful clamping action.

STAINLESS STEEL M/D CLAMP

STRENGTH	WEIGHT (Kg)	PART No.
MEDIUM DUTY	0.15	VESX45



Twin Tungsten carbide teeth to provide a very reliable earth.

Designed for small drums and containers.

Ergonomic design.

CLAMP WITH SPIRAL CABLE

CABLE LENGTH (m)	WEIGHT (Kg)	PART No.
3	0.35	CAB1G03
5	0.70	CAB1G05
10	1.30	CAB1G10



Coiled cable retracts when not in use (1:10 extension ratio).

Proven to hold its shape after at least 20,000 extensions.

Tested against 174 different chemicals with superior abrasion resistance.

Codes for cable only, please see matrix for code to include clamp

CLAMP WITH STATIC DISCHARGE REELS

REEL LENGTH (m)	WEIGHT (Kg)	PART No.
6.1	1.25	R20
9.2	2.25	R30
15.2	2.25	R50



Self-retracting Yellow hytrel coated galvanised steel cable, 3 reel's available with varying length's.

Codes for cable only, please see matrix for code to include clamp

PRODUCT MATRIX



To get the Part Number for the correct clamp and reel you require, please follow the product matrix:

Always start the Part Number with the clamp code i.e.



VESX90 / VESX45

Then add the Part Number for either the cable or the reel.

CAB1G03: 3m GREEN SPIRAL CABLE

CAB1G05: 5m GREEN SPIRAL CABLE

CAB1G10: 10m GREEN SPIRAL CABLE

R20: SELF-RETRACTING 6.1m REEL

R30: SELF-RETRACTING 9.2m REEL

R50: SELF-RETRACTING 15.2m REEL

For example, if you required a Heavy Duty clamp with a 9.2m reel:

VESX90 + R30

=VESX90/R30

FINAL ASSEMBLY:



INTRODUCTION

Introduction:

An early streamer device is powered by storing energy from the naturally occurring ambient electrical field, which builds up considerably, (as much as several thousand volts per metre) - when a storm approaches. This electrical energy is collected and stored within the device. Just before a lightning strike occurs there is a rapid increase in the electrical field and this is detected by the EC-SAT. This in turn triggers the device to release the stored energy in the form of an ionization at the tip of the air terminal. This encourages the formation of rising discharge (upward leader) from the EC-Sat in advance of the naturally occurring upward leaders from other points on the structure being protected. The principle being that should a lightning strike occur it would be attracted to the streamer provided by the EC-SAT and then would be conducted safely to earth by the down conductors/earth.

Basic Installation Guide:

A detailed evaluation should be made before the installation; the EC-SAT should always represent the highest point of the building requiring protection. The air terminal should always be sited at least 2 metres above the area it is intended to protect. When making an assessment, consideration must be given to any of the vantage points. These may include any outbuildings on the roof, the buildings gables, metallic or brick chimneys.

The EC-SAT may also be mounted on a free standing pole / tower to provide protection for an open area of ground, e.g. recreational areas. If more than one EC-SAT is required to protect a single construction, then it is necessary to inter-connect each device by a conductor conforming to relevant standards. Examples of this are: If the horizontal length of the building is greater than the vertical drop or the height of the building is greater than 28 metres. All conductors should take the shortest and most direct route to earth, avoiding sharp angles and curvatures. The radius of any curvature must be greater than 20cms. Each down conductor will be linked to its own earth, usually copperbond earth rods.

EC-SAT DEVICES / ACCESSORIES

DESCRIPTION	RADIUS COVERAGE (m)	PART No.
EARLY STREAMER HEAD	40	EC-SAT500
EARLY STREAMER HEAD	65	EC-SAT750
EARLY STREAMER HEAD	75	EC-SAT1000

DESCRIPTION	PART No.
COUPLER FOR EC-SAT UNITS	EC-SATCOUP
EARLY STREAMER EMISSION EXTENSION SHAFT 2m SIDE MOUNTED	EC-SHAFT02
EARLY STREAMER EMISSION EXTENSION SHAFT 2m FLAT MOUNTED	EC-SHAFT02/FT
EC-SAT TESTER (PORTABLE)	EC-SHAFT03



BULK MATERIALS

Kingsmill Industries (UK) Ltd are aware that Earthing & Lightning Protection forms just a fragment of the materials required in construction projects.

We will give consideration and assistance in all areas of your project requirement and our sales team are here to assist you with any of your procurement needs.

Onshore or Offshore, Churches to Oil Platforms our team of dedicated professionals will help wherever possible to solve any procurement issues you may have.

Kingsmill are proud to have supplied a range of bulk materials, including Electrical, Telecoms and Consumables to customers and projects located around the world.

We are happy to adapt and diversify to suit individual customers and project's needs;

All materials being shipped are packaged to the highest standard to ensure the materials arrive at the desired destination in excellent condition. Great care is taken in labelling the products to ensure the client can easily identify all receiving materials.

A sample of Projects we have worked on:

United Kingdom □ Wembley Stadium □ Beachyhead Lighthouse □ Harrods Store London □ Orange, Vodaphone etc. Masts & Towers nationwide

□ Novartis Petroleum Complex □ Bombardier Distribution Complex □ RAF Lakenheath □ Houses of Parliament. □ Mount Vernon Hospital

□ The New Wembley Stadium □ Channel Tunnel □ Railtrack Group PLC (RT Group PLC) □ Stormont Castle □ Upton Park, West Ham United Football Club

□ Waterfront Hall □ Woolwich Barracks □ St. Josephs Hospital □ Barbican Arts Centre □ Stamford Bridge, Chelsea Football Club □ Kings College London

□ Jessops Monument □ McLaren Technology Centre

Kuwait □ Gulf Investment Company □ Kuwait Oil Company

Kazakhstan □ AGIP Kashagan Field Development Project □ Kashagan Field Development Project □ Tranche 1 & 2 □ Eskene West Rail Project

United Arab Emirates □ Fujairah Water & Power Project (Union Water & Electricity) Feb 03 □ Trade Centre Abu Dhabi □ City Centre UAE □ Festival City UAE

□ Internet City UAE □ ADEWA Hospital □ ADEWA Sub Station □ ADWEA Contract No G1408 (5 New 33/11kV Sub Stations) – 2004

□ ADWEA Contract No G1332B (New 132/11kV Substation Marina Mall) – 2004 □ ADWEA Contract No N1999 132/11kV Substations E14 & W47

□ GCC Interconnection 400KV OHL from Shuweihat S/S to Sila S/S □ ASAB Full Field Development Project

□ N□11448 (220kV SWITCHING STATION AT ASAB□2) □ 400/132kV Grid Station at Fujairah City □ Yahsat SGS Power Project □ Fujairah 400KV Grid Station Transco N5629

Qatar □ Multi□Storey Car Park – Al Dafna (**ASHGHAL**) □ Zekreet Office Building (**RASGAS**) □ New Training Center – Dukhan (**Qatar Petroleum**)

□ Communication Building at Shahaniya & Miknis (**Ministry of Interior**) □ Maritime Coastal Station at Al Wusail (**Q□TEL**) □ Phase VIII Substation (**KAHRAMAA**)

□ Interim Data Center (**Qatar Foundation**) □ Police Station, Communication Building at Zubara (**Ministry of Interior**) □ OSS (**QTEL**) □ QDC Wadi Sail (**QTEL**)

□ Qatar Aluminum (**QATALUM**) □ Viva Bahria VB□02□09□11□17□22□23 (**The Pearl Qatar**) □ GTL Pearl 299 □ Falcon Tower □ New Diplomatic Area Zone 66

□ Barzan Camp □ Guard Residence at Al Wajba □ QCS 282 □ Marwa Tower □ GTL Pearl – Site Preparation □ 2B+G+14 Storey Residential Apartment

□ Freej Abdel Aziz □ GTL Pearl – Effluent Treatment Plant □ Buzwair Building □ Golden Bay Tower □ Salwa Resort □ Dukhan Tower □ Al Wajba Guard Residence

□ Gas Plant – Industrial Area □ Sky Guard – Qatar Army □ Al Mana Mall □ G+7 Building □ Dr. Ali Fteis Office Tower □ Abdul□Ghani Commercial Tower

□ Circular Tower □ 2B+G+11 Residential Building □ Circular Tower □ Golden Sand Hotel □ Al Ramez Tower □ Al Waab Mall □ Al Nakheel Tower

□ Cambridge School – Al Helal □ Al Seelyia Tower □ Cable Factory – Al Jaber Engineering □ Al Muftah Tower □ Buzweir Building □ Nabina Villa

□ Sheikh Suhaim Villa □ Qatar Power Transmission System Expansion Phase VIII 0 Substation GTC/144/2006 □ Qatar Power Transmission System Expansion □ Phase IX □ GTC/240B/2008

Lebanon □ ABC Mall, Ashrafieh, Lebanon □ Water Pumping Stations, Tripoli Lebanon □ St Joseph Hospital, Beirut Lebanon □ St Georges Hospital, Beirut Lebanon

□ Rayak Hospital, Bekaa Lebanon □ Mazraa Public School, Beirut Lebanon □ American Embassy, Awkar Lebanon □ Loulou'a Residential building, Beirut Lebanon

□ Metropolitan City Center MCC □ Broumana High School □ Saaf Villa □ Saint Georges Towers □ 4 Points Sheraton Hotel □ Ogero (Ministry of Telecom)

Yemen □ PTC Yemen (Public Telecommunication Company) □ Spacetel Yemen (GSM Operator) □ Telecom Towers

Liberia □ Lonestar Communication, Liberia (GSM Operator) **Ghana** □ Scancom Ghana (GSM Operator)

Algeria □ Terga Power Plant □ Al Salah Project □ Skikda Project □ Krechba Site □ In Salah Compression Project □ In Amenas Gas Project □ In Salah Gas Southern Fields Development

Afghanistan □ MTF Project, MNB, Tarin Kowt, Uruzgan Province

Cyprus □ VTT Vassiliko Oil Terminal & Jetty in Vasilikos

Egypt □ WDDM Main Compression Phase VII □ APC, Lube Oil Complex Rehabilitation Project

Iraq □ Early Production System (EPS) & Brownfield Facilities, Southern Iraq □ Shell Majnoon Project, Green Field Site □ Shell Majnoon Project, Brown Field Site

□ Kurdistan□132/33/11KV SS at Stage 6 in Dohuk Governate

Jordan □ Qatrana Power Station □ FAJR Upgrade of Aqaba Compression Station

KSA □ Jubail Export Refinery Project □ Jubail Project, Grounding Material

Libya □ Gas Utilization Project □ Phase 2 □ Chemical Injection Packages □ LP Gas Compressor Station □ Zueitina Oil Co. □ Waha Oil Company

Sri Lanka □ Hambantota International Airport

Vietnam □ SU TU NAU Field Development

QUALITY CONTROL

Kingsmill Industries (UK) Ltd is an ISO 9001:2008 registered company.

The company aims to provide the highest standards of service and customer care without compromising quality or price.

Undeniably, quality assurance is of paramount importance to the company and, to ensure this, all products are manufactured in accordance with BS EN 62305, BS EN 50164 and BS 7430.



CERTIFICATE No. 7077
ISO 9001 : 2008

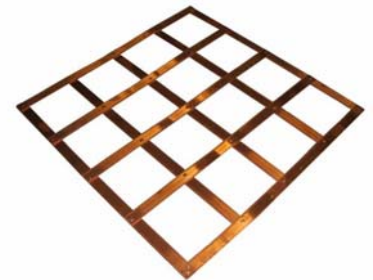

PART NUMBER INDEX

<u>PART NO:</u>	<u>PG NO:</u>	<u>PART NO:</u>	<u>PG NO:</u>	<u>PART NO:</u>	<u>PG NO:</u>	<u>PART NO:</u>	<u>PG NO:</u>	<u>PART NO:</u>	<u>PG NO:</u>	<u>PART NO:</u>	<u>PG NO:</u>
10020	73	BFW10	32	CAST	44	CELV1615	59	DRST16	2	EBAR28-2/T	28
10020/4	73	BFW12	32	CATB16	60	CELV1620	59	DRST20	2	EBAR30	26
10020/4-ENC	73	BHS0625	32	CATB50	60	CELV1625	59	DTB2/ART	76	EBAR30/T	26
10020/4-ENCM	73	BHS0635	32	CATB70	60	CELV1630	59	DWPB10	4	EBAR30-1	27
10650/LED	74	BHS0816	32	CATB95	60	CGUV150	17	DWSS10	6	EBAR30-1/T	27
10651/LED	74	BHS0825	32	CAWH	44	CGUV16	17	EARTH-BAR	75	EBAR30-2	28
A2CSKSLT01	33	BHS0835	32	CB200/10/7	23	CGUV70	17	EBAR10	26	EBAR30-2/T	28
A2CSKSLT1.5-10	33	BHS1025	32	CB200/16/9	23	CLA2510	15	EBAR10/T	26	EBAR6	26
A2FN06	32	BHS1035	32	CB200/25/11	23	CLA2530	15	EBAR1000	29	EBAR6/T	26
A2FN08	32	BHS1225	32	CB200/50/11	23	CLA4012	15	EBAR1000/T	29	EBAR600	29
A2FN10	32	BHS1235	32	CB200/6/7	23	CLA5060	15	EBAR10-1	27	EBAR600/T	29
A2FN12	32	BM08253SS	58	CB200/70/13	23	CLJA16	16	EBAR10-1/T	27	EBAR6-1	27
A2FW06	32	BM08HS	58	CB200/95/13	23	CLJA20	16	EBAR10-2	28	EBAR6-1/T	27
A2FW08	32	BM253FC	58	CB400/10/7	23	CLUB16	15	EBAR10-2/T	28	EBAR6-2	28
A2FW10	32	BM253HS	58	CB400/16/9	23	CLUB16-2	16	EBAR12	26	EBAR6-2/T	28
A2FW12	32	BSCW006	45	CB400/25/11	23	CLUB20	15	EBAR12/T	26	EBAR8	26
A2HS0616	32	BSCW016	45	CB400/50/11	23	CLUB20-2	16	EBAR12-1	27	EBAR8/T	26
A2HS0825	32	BSCW016/T	47	CB400/6/7	23	CLUB25	15	EBAR12-1/T	27	EBAR8-1	27
A2HS1012	32	BSCW025	45	CB400/70/13	23	CLUB25-2	16	EBAR12-2	28	EBAR8-1/T	27
A2HS1016	32	BSCW025/T	47	CB400/95/13	23	CLUB30	15	EBAR12-2/T	28	EBAR8-2	28
A2HS1025	32	BSCW035	45	CBHD1006	39	CLUB50	15	EBAR14	26	EBAR8-2/T	28
A2HS1035	32	BSCW035/T	47	CBHD2530	39	CLUG10	17	EBAR14/T	26	EBOSS2525M08	21
A2HS1230	32	BSCW050	45	CBHD2530/T	39	CLUG15S	17	EBAR14-1	27	EBOSS3030M08	21
A2HS1240	32	BSCW050/T	47	CBHD2560	39	CLUG16	17	EBAR14-1/T	27	EBOSS3030M10	21
A2SPW06	32	BSCW070	45	CBHD2560/T	39	CLUG20	17	EBAR14-2	28	EBOSS3040M08	21
A2SPW08	32	BSCW070/T	47	CBHD3130	39	CLUG20S	17	EBAR14-2/T	28	EBOSS3040M10	21
A2SPW10	32	BSCW095	45	CBHD3830	39	COUP16	2	EBAR16	26	EBOSS3050M08	21
A2SPW12	32	BSCW095/T	47	CBHD3860	39	COUP20	2	EBAR16/T	26	EBOSS3050M10	21
AATB10	60	BSCW120	45	CBHD5010	39	CPF	61	EBAR16-1	27	EBOSS4030M10	21
AATB16	60	BSCW120/T	47	CBHD5060	39	CPIT	10	EBAR16-1/T	27	EBOSS4030M12	21
APF	61	BSCW150	45	CBHD5060/T	39	CPIT/LW	11	EBAR16-2	28	EBOSS4040M10	21
ARWB	18	BSCW150/T	47	CBHD6060	39	CRWB	18	EBAR16-2/T	28	EBOSS4040M12	21
ATAR1005	59	BSCW185	45	CBHD7506	39	CTBA1215	35	EBAR18	26	EBOSS4050M10	21
ATAR1010	59	BSCW185/LS	48	CBT200/10/7	23	CTBA1215	35	EBAR18/T	26	EBOSS4050M12	21
ATAR1605	59	BSCW185/T	47	CBT200/16/9	23	CTBA1230	35	EBAR18-1	27	EBOSS5030M10	21
ATAR1610	59	BSCW240	45	CBT200/25/11	23	CTBA1330	35	EBAR18-1/T	27	EBOSS5030M12	21
ATAR1615	59	BSCW240/LS	48	CBT200/50/11	23	CTBA2015	35	EBAR18-2	28	EBOSS5040M10	21
ATAR1620	59	BSCW240/T	47	CBT200/6/7	23	CTBA2030	35	EBAR18-2/T	28	EBOSS5040M12	21
ATAR1625	59	BSCW300	45	CBT200/70/13	23	CTBA2530	35	EBAR20	26	EBOSS5050M10	21
ATAR1630	59	BSCW300/LS	48	CBT200/95/13	23	CTBA2540	35	EBAR20/T	26	EBOSS5050M12	21
ATBA12515	42	BSCW300/T	47	CBT400/10/7	23	CTBA2560	35	EBAR20-1	27	EBP1	19
ATBA2030	42	BSCW400	45	CBT400/16/9	23	CTBA3020	35	EBAR20-1/T	27	EBP1-T	20
ATBA2530	42	BSCW400/LS	48	CBT400/25/11	23	CTBA3030	35	EBAR20-2	28	EBP2	19
ATBA2560	42	BSCW400/T	47	CBT400/50/11	23	CTBA3040	35	EBAR20-2/T	28	EBP2P	19
ATBA3030	42	BZPFN06	33	CBT400/6/7	23	CTBA3050	35	EBAR22	26	EBP2P-08	19
ATBA4060	42	BZPFN08	33	CBT400/70/13	23	CTBA3160	35	EBAR22/T	26	EBP2P-08-T	20
ATBA5060	42	BZPFN10	33	CBT400/95/13	23	CTBA3830	35	EBAR22-1	27	EBP2P-T	20
ATCR1005	59	BZPFN12	33	CC08	43	CTBA3850	35	EBAR22-1/T	27	EBP2-T	20
ATCR1010	59	BZPFW06	33	CCBL	43	CTBA3860	35	EBAR22-2	28	EBP4	20
ATCR1605	59	BZPFW08	33	CCBN	43	CTBA4030	35	EBAR22-2/T	28	EBP4-T	20
ATCR1610	59	BZPFW10	33	CCGY	43	CTBA4040	35	EBAR24	26	EC-SAT1000	80
ATCR1615	59	BZPFW12	33	CCGY016	46	CTBA4050	35	EBAR24/T	26	EC-SAT500	80
ATCR1620	59	BZPHS0625	33	CCGY025	46	CTBA4060	35	EBAR24-1	27	EC-SAT750	80
ATCR1625	59	BZPHS0825	33	CCGY035	46	CTBA5030	35	EBAR24-1/T	27	EC-SATCOUP	80
ATCR1630	59	BZPHS1035	33	CCGY050	46	CTBA5040	35	EBAR24-2	28	EC-SHAFT02	80
BBAB	18	BZPSPW06	33	CCGY070	46	CTBA5050	35	EBAR24-2/T	28	EC-SHAFT02/FT	80
BBCB	18	BZPSPW08	33	CCGY095	46	CTBA5060	35	EBAR26	26	EC-SHAFT03	80
BCSW1.5-10	33	BZPSPW10	33	CCGY120	46	D-24/BNC	76	EBAR26/T	26	ELINK	25
BCSW1.5-12	33	BZPSPW12	33	CCGY150	46	DEN050	65	EBAR26-1	27	ELINK/T	25
BENT01	7	C Crimps	63	CCGY185	46	DP10-LSA180	75	EBAR26-1/T	27	ERCB1004	1
BENT02	7	CA08	44	CCGY240	46	DP1-LSA180	75	EBAR26-2	28	ERCB1604	1
BFN06	32	CAB1G03	79	CCGY300	46	DRHD16	4, 6	EBAR26-2/T	28	ERCB1605	1
BFN08	32	CAB1G05	79	CCGY400	46	DRHD20	4, 6	EBAR28	26	ERCB1606	1
BFN10	32	CAB1G10	79	CCST	43	DRHD25	4, 6	EBAR28/T	26	ERCB1608	1
BFN12	32	CABL	44	CCWH	43	DRSP16	4, 6	EBAR28-1	27	ERCB1610	1
BFW06	32	CABN	44	CELV1605	59	DRSP20	4, 6	EBAR28-1/T	27	ERCB2004	1
BFW08	32	CAGY	44	CELV1610	59	DRSP25	4, 6	EBAR28-2	28	ERCB2005	1

<u>PART NO.:</u>	<u>PG NO.:</u>	<u>PART NO.:</u>	<u>PG NO.:</u>	<u>PART NO.:</u>	<u>PG NO.:</u>	<u>PART NO.:</u>	<u>PG NO.:</u>	<u>PART NO.:</u>	<u>PG NO.:</u>	<u>PART NO.:</u>	<u>PG NO.:</u>
ERCB2006	1	FBT400/16/9	22	LTC240,16	62	P-GAU-WH	48	RBCA16	61	TCGN253	36
ERCB2008	1	FBT400/25/11	22	LTC25,06	62	P-GAU-ST	48	RBCC-08	61	TCGN253LS	37
ERCB2010	1	FBT400/35/11	22	LTC25,08	62	PAVG	48	RBCC16	61	TCGN253LS/50	37
ERSC1504	3	FBT400/50/11	22	LTC25,10	62	PBAR5	10	SBC1	64	TCGN256	36
ERSC1604	3	FBT400/6/7	22	LTC25,12	62	PBAR5/LW	11	SBC10	64	TCGN256LS	37
ERSC1605	3	FBT400/70/13	22	LTC300,12	62	PBAR5/PP	12	SBC2	64	TCGN506	36
ERSC1606	3	FBT400/95/13	22	LTC300,14	62	PBAR7	10	SBC20	64	TCGN506LS	37
ERSC1608	3	FCB1201	40	LTC300,16	62	PBAR7/LW	11	SBC30	64	TCGY253	36
ERSC1610	3	FCB1515	40	LTC35,06	62	PBAR7/PP	12	SBC4	64	TCLD253	37
ERSC2004	3	FCB1925	40	LTC35,08	62	PBFN10	33	SBC40	64	TCST253	36
ERSC2005	3	FCB2530	40	LTC35,10	62	PBFN12	33	SBC50	64	TCTD1215	38
ERSC2006	3	FCB2535	40	LTC35,12	62	PBFW10	33	SBC8	64	TCTD1215	38
ERSC2008	3	FCB3050	40	LTC400,12	62	PBFW12	33	SCEP615	14	TCTD1230	38
ERSC2010	3	FCB3260	40	LTC400,14	62	PBHS1025	33	SCEP630	14	TCTD1330	38
ERSC2504	3	FCB3760	40	LTC400,16	62	PBHS1035	33	SCEP915	14	TCTD2015	38
ERSC2505	3	FCB4560	40	LTC50,06	62	PBHS1225	33	SCEP930	14	TCTD2030	38
ERSC2506	3	FCB5080	40	LTC50,08	62	PBHS1235	33	SDTC253	57	TCTD2530	38
ERSC2508	3	FCBT1201	41	LTC50,10	62	PBSPW10	33	SF050	67	TCTD2540	38
ERSC2510	3	FCBT1515	41	LTC50,12	62	PBSPW12	33	SHBL253P	51	TCTD2560	38
ERSS1604	5	FCBT1925	41	LTC70,08	62	PCBL08P	50	SHBN253B	51	TCTD3020	38
ERSS1605	5	FCBT2530	41	LTC70,10	62	PCBL08P/AD	52	SHBN253P	51	TCTD3030	38
ERSS1606	5	FCBT2535	41	LTC70,12	62	PCBL08P/BUTT	51	SHGN253P	51	TCTD3040	38
ERSS1608	5	FCBT3050	41	LTC70,14	62	PCBL253P	50	SHGY253B	51	TCTD3050	38
ERSS1610	5	FCBT3260	41	LTC70,16	62	PCBL253P/AD	52	SHGY253P	51	TCTD3160	38
ERSS2004	5	FCBT3760	41	LTC95,08	62	PCBN08B	50	SHST253P	51	TCTD3830	38
ERSS2005	5	FCBT4560	41	LTC95,10	62	PCBN08B/AD	52	SHWH253P	51	TCTD3850	38
ERSS2006	5	FCBT5080	41	LTC95,12	62	PCBN08B/BUTT	51	SP-30	76	TCTD3860	38
ERSS2008	5	GAVG	48	LTC95,14	62	PCBN08P	50	SP-48	76	TCTD4030	38
ERSS2010	5	HDCS08	49	LTC95,16	62	PCBN08P/AD	52	SPD240	70	TCTD4040	38
ERSS2504	5	HDCS50	49	MARC01	9	PCBN08P/BUTT	51	SPD415	70	TCTD4050	38
ERSS2505	5	HDCS70	49	MARC02	9	PCBN203B	50	SPD-PV1000	77	TCTD4060	38
ERSS2506	5	HDCS95	49	MDA203	49	PCBN253B	50	SPD-PV600	77	TCTD5030	38
ERSS2508	5	INSU1	29	MDA253	49	PCBN253B/AD	52	SQCA08	54	TCTD5040	38
ERSS2510	5	INSU2	29	MDA253P	49	PCBN253P	50	SQCA253	53	TCTD5050	38
FB200/10/7	22	INSU3	29	MDA256	49	PCBN253P/AD	52	SQCC253	53	TCTD5060	38
FB200/120/17	22	INSU4	29	MDA506	49	PCBN506B	50	SQCC25308	55	TCWH253	36
FB200/150/17	22	KES-15	13	MDA506P	49	PCGN253P	50	SQCC25350	55	TEA2550	19
FB200/16/9	22	KES-15-DBL	13	MDC203	49	PCGY08B	50	SQCC25370	55	TEC1670	19
FB200/25/11	22	KES-16	13	MDC253	49	PCGY08B/AD	52	SQCC25395	55	TEC2550	19
FB200/35/11	22	KES-16-DBL	13	MDC253LD	49	PCGY08B/BUTT	51	SQCC256	53	TEC70120	19
FB200/50/11	22	KES-20	13	MDC253P	49	PCGY08P	50	SQCC313	53	TEEA08	55
FB200/6/7	22	KES-20-DBL	13	MDC254	49	PCGY08P/AD	52	SQCC406	53	TEEC08	55
FB200/70/13	22	KES-34	13	MDC256	49	PCGY08P/BUTT	51	SQCC506	53	TINS1/2	65
FB200/95/13	22	KES-34-DBL	13	MDC256P	49	PCGY203B	50	SQCW08	54	TPA203	52
FB400/10/7	22	KES-58	13	MDC313	49	PCGY253B	50	SQCW50	54	TPA253	52
FB400/120/17	22	KES-58-DBL	13	MDC316	49	PCGY253B/AD	52	SQCW70	54	TPC203	52
FB400/150/17	22	LCEM630	14	MDC383	49	PCGY253P	50	SQCW95	54	TPC253	52
FB400/16/9	22	LCEM930	14	MDC385	49	PCGY253P/AD	52	SY1-C-40X	72	TPC253P	52
FB400/25/11	22	LSPD240	71	MDC386	49	PCST08P	50	SY2-C-40X	72	UNP250	67
FB400/35/11	22	LSPD415	71	MDC404	49	PCST08P/AD	52	SY2-D	72	VESX45	79
FB400/50/11	22	LTC120,10	62	MDC406	49	PCST08P/BUTT	51	SY2-D-LED	72	VESX90	79
FB400/6/7	22	LTC120,12	62	MDC503	49	PCST253P	50	TA08	58		
FB400/70/13	22	LTC120,14	62	MDC504	49	PCST253P/AD	52	TABL12515	42		
FB400/95/13	22	LTC120,16	62	MDC506	49	PCWH08P	50	TABL2030	42		
FBT200/10/7	22	LTC150,10	62	MDC506P	49	PCWH08P/AD	52	TABL253	42		
FBT200/120/17	22	LTC150,12	62	MPAT	60	PCWH08P/BUTT	51	TABN253	42		
FBT200/150/17	22	LTC150,14	62	OH10A	51	PCWH253P	50	TAGN253	42		
FBT200/16/9	22	LTC150,16	62	OH10C	51	PCWH253P/AD	52	TAGY253	42		
FBT200/25/11	22	LTC16,06	62	OH8C	51	PP-10	33	TAST253	42		
FBT200/35/11	22	LTC16,08	62	OHAC	51	PP-12	33	TAWH253	42		
FBT200/50/11	22	LTC16,10	62	OTCA253	56	PPIT-G	12	TC08	58		
FBT200/6/7	22	LTC16,12	62	OTCC253	56	PTTC253	56	TC50	57		
FBT200/70/13	22	LTC185,12	62	OTCC316	56	R20	79	TC70	57		
FBT200/95/13	22	LTC185,14	62	OTCC405	56	R30	79	TC95	57		
FBT400/10/7	22	LTC185,16	62	P-GAU-BN	48	R50	79	TCBL253	36		
FBT400/120/17	22	LTC240,12	62	P-GAU-BL	48	RBA16	61	TCBN253	36		
FBT400/150/17	22	LTC240,14	62	P-GAU-GY	48	RBC16	61	TCGN/Y253	37		

COMPANY LOCATION

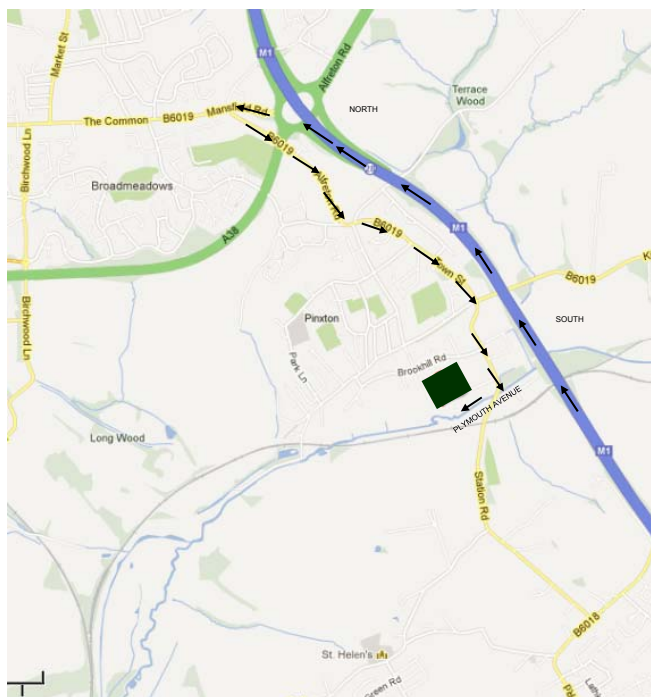

The map to the left provides detailed instructions on how to locate our site from the M1.

Use the Kingsmill Industries (UK) Ltd sign below for instructions for entry to the site:

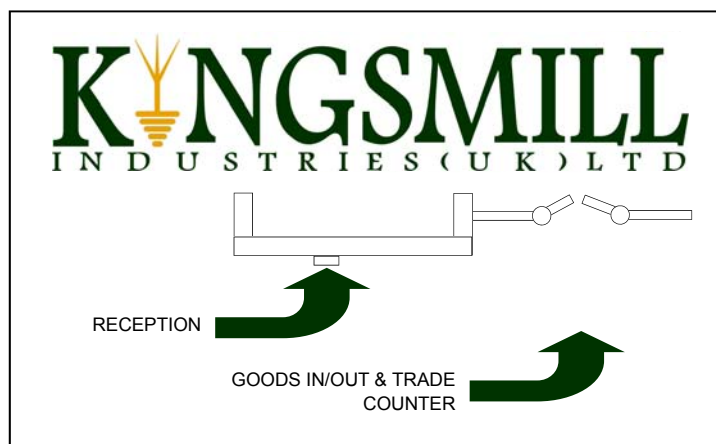

Carriage:

Carriage will be paid on all orders over £450 net, despatched as one consignment on a 2-3 day service to (UK) mainland destinations only. All other deliveries will be charged at cost.

Non Deliveries:

All non deliveries or shortage claims must be made within two working days of receipt of invoice.

Copper LME base rate:

As copper is a commodity item which is bought and sold on the London Metal Exchange (LME) daily, the price of copper-based items must fluctuate in line with the LME rate. To keep these variations to a minimum, copper items are sold in price bands relating to the LME base rate. For todays rate please telephone: +44 (0) 1773 510001.

Conductor Lengths:

Due to the manufacturing tolerances is not always possible to guarantee the exact lengths when supplying conductor. We therefore reserve the right to supply and invoice within 5% of the quantity ordered.

Conditions of sale: Our standard terms and conditions of sale apply and can be obtained upon request.

VAT: Will be charged at the appropriate rate at the time of invoice.

Changes: Kingsmill Industries (UK) Ltd reserve the right to alter the design specifications and prices of items within our product range without prior notice.



COMMITMENT TO SERVICE

Commitment to Product Quality & Service . . .

At Kingsmill Industries (UK) Ltd, our wealth of knowledge in structural lightning protection, earthing and transient overvoltage protection gives our customers the ability to offer leading edge product development and unparalleled technical support.

Kingsmill Industries (UK) Ltd is an ISO 9001 registered company and this is where our commitment to quality begins.

This commitment to quality follows throughout all aspects of the company including manufacture, development and customer support and service.

A commitment to excellent customer service is an integral part of the Kingsmill ideology.

Part of this involves maintaining excellent stock levels on many of our core product ranges ensuring efficient despatch schedules.

With extensive experience and technical expertise, we can in some cases manufacture 'specials' based upon an unusual request to meet the exact specification of the customer.

NOTES

Multiple horizontal lines for notes.



